

Tracer[®] EX2

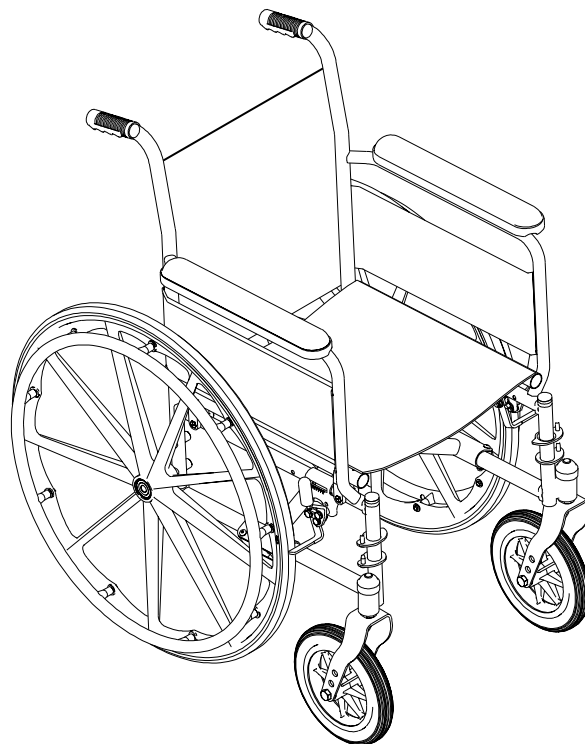

DEALER: This manual **MUST** be given to the user of the product.

USER: **BEFORE** using this product, read this manual and save for future reference.

For more information regarding
Invacare products, parts, and services,
please visit www.invacare.com



Yes, you can.

⚠ WARNING

A QUALIFIED TECHNICIAN MUST PERFORM THE INITIAL SET UP OF THIS WHEELCHAIR. ALSO, A QUALIFIED TECHNICIAN MUST PERFORM ALL PROCEDURES SPECIFICALLY INDICATED IN THE MANUAL.

WHEELCHAIR USERS: DO NOT SERVICE OR OPERATE THIS EQUIPMENT WITHOUT FIRST READING AND UNDERSTANDING (1) THE OWNER'S OPERATOR AND MAINTENANCE MANUAL AND (2) THE SEATING SYSTEM'S MANUAL (IF APPLICABLE). IF YOU ARE UNABLE TO UNDERSTAND THE WARNINGS, CAUTIONS, AND INSTRUCTIONS, CONTACT INVACARE TECHNICAL SUPPORT BEFORE ATTEMPTING TO SERVICE OR OPERATE THIS EQUIPMENT - OTHERWISE INJURY OR DAMAGE MAY RESULT.

DEALERS AND QUALIFIED TECHNICIANS: DO NOT SERVICE OR OPERATE THIS EQUIPMENT WITHOUT FIRST READING AND UNDERSTANDING (1) THE OWNER'S OPERATOR AND MAINTENANCE MANUAL, (2) THE SERVICE MANUAL (IF APPLICABLE) AND (3) THE SEATING SYSTEM'S MANUAL (IF APPLICABLE). IF YOU ARE UNABLE TO UNDERSTAND THE WARNINGS, CAUTIONS AND INSTRUCTIONS, CONTACT INVACARE TECHNICAL SUPPORT BEFORE ATTEMPTING TO SERVICE OR OPERATE THIS EQUIPMENT - OTHERWISE, INJURY OR DAMAGE MAY RESULT.

NOTE: Updated versions of this manual are available on www.invacare.com.

TABLE OF CONTENTS

REGISTER YOUR PRODUCT	6
SPECIAL NOTES	9
LABEL LOCATION	11
TYPICAL PRODUCT PARAMETERS	12
SECTION 1—GENERAL GUIDELINES	13
Stability - All Models	13
Anti-Tippers.....	13
Operating Information.....	14
Weight Training	15
Weight Limitation.....	15
SECTION 2—SAFETY/HANDLING OF WHEELCHAIRS	16
Safety/Handling of Wheelchairs.....	16
Stability and Balance.....	16
Coping With Everyday Obstacles.....	17
A Note to Wheelchair Assistants	17
Reaching, Leaning and Bending Forward.....	18
Reaching and Leaning Backwards.....	18
Tipping.....	18
Method 1 - Wheelchair With Step Tubes.....	19
Method 2 - Wheelchair Without Step Tubes	19
Stairways.....	20
Escalators.....	21
Transferring To and From Other Seats	21
Unfolding and Folding Wheelchair	22
Unfolding.....	22
Folding Wheelchair.....	23
Folding Hammock or Sling Seat Models.	24
SECTION 3—SAFETY INSPECTION/TROUBLESHOOTING	25
Safety Inspection Checklist.....	25
Inspect/Adjust Initially	25
Inspect/Adjust Weekly	26
Inspect/Adjust Monthly	26
Inspect/Adjust Periodically	27

TABLE OF CONTENTS

Troubleshooting.....	27
Maintenance	28
Maintenance Safety Precautions	28
Suggested Maintenance Procedures	28
SECTION 4—FRONT RIGGINGS	29
Installing/Removing Front Riggings	29
Installing.....	29
Removing	29
Adjusting Footplate Height.....	30
Spring Button	30
Bolt-In-Place	30
Fixed Frame.....	31
Raising/Lowering Elevating Legrest Assembly.....	32
Installing Impact Guards/Calf Strap	32
Replacing Heel Loop.....	33
SECTION 5—ARMS	35
Adjusting Armrest Height.....	35
Removing/Installing Armrests	36
Removing Armrest.....	36
Installing Armrest.....	36
SECTION 6—SEAT AND BACK	37
Replacing Back Upholstery	37
Replacing Seat Upholstery	37
Adjusting the Seat Width.....	38
Swingaway Front Riggings	38
Fixed Frame.....	40
Removing Lower Mounting Hardware	40
Removing Upper Mounting Hardware	40
SECTION 7—REAR WHEELS	41
Removing/Installing Rear Wheels	41
Permanent Axles	41
Replacing Rear Wheel Handrim.....	42
Replacing/Repairing Rear Wheel Tire.....	42
SECTION 8—FRONT CASTERS	43

TABLE OF CONTENTS

Installing/Replacing Six or Eight-Inch Front Casters and Forks	43
Adjusting Forks	44
Replacing Front Casters.....	44
Replacing/Repairing Front Caster Tire.....	45
SECTION 9—ANTI-TIPPERS/WHEEL LOCKS	46
Installing/Adjusting Anti-tippers	46
Installing Anti-Tippers	46
Adjusting the Anti-Tippers.....	47
Using/Adjusting Patient Operated Wheel Locks.....	48
Using Patient Operated Wheel Locks	48
Adjusting Patient Operated Wheel Locks	49
SECTION 10—SEAT TO FLOOR	50
Changing Seat-to-Floor Height.....	50
SECTION 11—OPTIONS	52
Installing Amputee Bracket.....	52
Installing Crutch and Cane Carrier	53
Installing the Seat Positioning Strap.....	54
LIMITED WARRANTY	55

REGISTER YOUR PRODUCT

The benefits of registering:

1. Safeguard your investment.
2. Ensure long term maintenance and servicing of your purchase.
3. Receive updates with product information, maintenance tips, and industry news.
4. Invacare can contact you or your provider, if servicing is needed on your product.
5. It will enable Invacare to improve product designs based on your input and needs.

Register ONLINE at www.invacare.com

- or -

Complete and mail the form on the next page

Any registration information you submit will be used by Invacare Corporation only, and protected as required by applicable laws and regulations.



PRODUCT REGISTRATION FORM

Register ONLINE at www.invacare.com - or -
Complete and mail this form

Name _____

Address _____

City _____ State/Province _____

Zip/Postal Code _____

Email _____ Phone No. _____

Fold
here

Invacare Model No. _____ Serial No. _____

Purchased From _____ Date of Purchase: _____

1. Method of purchase: (check all that apply)

Medicare Insurance Medicaid Other _____

2. This product was purchased for use by: (check one)

Self Parent Spouse Other

3. Product was purchased for use at:

Home Facility Other

4. I purchased an Invacare product because:

Price Features (list features) _____

5. Who referred you to Invacare products? (check all that apply)

Doctor Therapist Friend Relative Dealer/Provider Other _____

Advertisement (circle one): TV, Radio, Magazine, Newspaper No Referral _____

6. What additional features, if any, would you like to see on this product?

Fold
here

7. Would you like information sent to you about Invacare products that may be available for a particular medical condition? Yes No

If yes, please list any condition(s) here and we will send you information by email and/or mail about any available Invacare products that may help treat, care for or manage such condition(s):

8. Would you like to receive updated information via email or regular mail about the Invacare home medical products sold by Invacare's dealers? Yes No

9. What would you like to see on the Invacare website?

10. Would you like to be part of future online surveys for Invacare products? Yes No

11. User's Year of birth: _____

If at any time you wish not to receive future mailings from us, please contact us at Invacare Corporation, CRM Department, 39400 Taylor Parkway, Elyria, OH 44035, or fax to 877-619-7996 and we will remove you from our mailing list.

To find more information about our products, visit www.invacare.com.

Cut Along Line



Fold
here

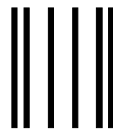

BUSINESS REPLY MAIL
FIRST-CLASS MAIL PERMIT NO. 196 ELYRIA OH

POSTAGE WILL BE PAID BY ADDRESSEE

NO POSTAGE
NECESSARY
IF MAILED
IN THE
UNITED STATES

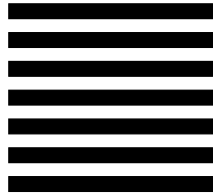

INVACARE CORPORATION
CRM DEPARTMENT
39400 TAYLOR PARKWAY
ELYRIA OH 44035-9836



Fold
here

Invacare Product Registration Form

Please Seal with
Tape Before Mailing

Cut Along Line



SPECIAL NOTES

Signal words are used in this manual and apply to hazards or unsafe practices which could result in personal injury or property damage. Refer to the following table for definitions of the signal words.

SIGNAL WORD	MEANING
DANGER	Danger indicates an imminently hazardous situation which, if not avoided, will result in death or serious injury.
WARNING	Warning indicates a potentially hazardous situation which, if not avoided, could result in death or serious injury.
CAUTION	Caution indicates a potentially hazardous situation which, if not avoided, may result in property damage.

NOTICE

THE INFORMATION CONTAINED IN THIS DOCUMENT IS SUBJECT TO CHANGE WITHOUT NOTICE.

WHEELCHAIR USER

As a manufacturer of wheelchairs, Invacare endeavors to supply a wide variety of wheelchairs to meet many needs of the end user. However, final selection of the type of wheelchair to be used by an individual rests solely with the user and his/her healthcare professional capable of making such a selection.

WHEELCHAIR TIE-DOWN RESTRAINTS AND SEAT RESTRAINTS

Wheelchair users should **NOT** be transported in vehicles of any kind while in wheelchairs. As of this date, the Department of Transportation has not approved any tie-down systems for transportation of a user while in a wheelchair, in a moving vehicle of any type.

It is Invacare's position that users of wheelchairs should be transferred into appropriate seating in vehicles for transportation and use be made of the restraints made available by the auto industry. Invacare cannot and does not recommend any wheelchair transportation systems.

SEAT POSITIONING STRAP

ALWAYS wear your seat positioning strap. Inasmuch as the seat positioning strap is an option on this wheelchair (you may order with or without the seat positioning strap), Invacare strongly recommends ordering the seat positioning strap as an additional safeguard for the wheelchair user. The seat positioning strap is a positioning belt only. It is not designed for use as a safety device withstanding high stress loads such as auto or aircraft safety belts. If signs of wear appear, belt **MUST** be replaced immediately.

Regarding restraints - seat positioning straps - it is the obligation of the DME dealer, therapists and other healthcare professionals to determine if a seating restraint is required to ensure the safe operation of this equipment by the user. Serious injury can occur in the event of a fall from a wheelchair.

⚠ WARNING

Invacare products are specifically designed and manufactured for use in conjunction with Invacare accessories. Accessories designed by other manufacturers have not been tested by Invacare and are not recommended for use with Invacare products.

LABEL LOCATION

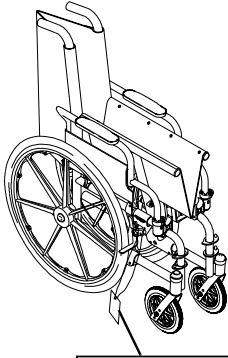

NO WHEELCHAIR HAS BEEN APPROVED FOR USE AS A SEATING SURFACE WITHIN A MOTOR VEHICLE. THIS LABEL IS FOR INFORMATIONAL PURPOSES ONLY. LIABILITY ISSUES WERE NOT CONSIDERED IN THE ATTACHMENT OF THIS LABEL.

AUCUN FAUTEUIL ROULANT N'A ÉTÉ APPROUVÉ POUR ÊTRE UTILISÉ COMME SIÈGE À L'INTÉRIEUR D'UN VÉHICULE MOTORISÉ. CETTE ÉTIQUETTE NE PEUT ÊTRE UTILISÉE QU'À TITRE D'INFORMATION ET N'A PAS ÉTÉ AFFICHÉE ICI POUR DES RAISONS DE RESPONSABILITÉ LÉGALE.

IMPORTANT NOTICE

The wheel locks on this wheelchair have been pre-set at the factory to comply with the Veterans Administration functional Standard 8320.01 of the Federal Register, paragraph 3.2.4.5.3. If these wheel locks do not meet your needs, follow instructions below.

⚠ CAUTION

Any wheel lock adjustments should embed wheel lock shoe at least 1/8" into tire when locked (3/16" on pneumatic tires).

INSTRUCTIONS FOR WHEEL LOCK ADJUSTMENTS

1. Loosen wheel lock mounting fastener, which runs through mounting bracket and frame.
2. Slide clamp toward rear wheel until wheel lock shoe is embedded into tire material at least 1/8" when handle is engaged to the lock position (3/16" for pneumatic tires).
3. Tighten mounting fastener to secure mounting bracket in desired location and recheck lock shoe embedding.
4. Inspect for correct locking action BEFORE actual use.

00078X021-0394

WEIGHT CAPACITY
250 LBS. (114 kgs.)
 REFER TO OWNER'S MANUAL
P/N 1111013

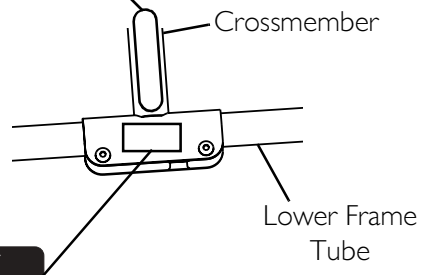

NOTE: On all adjustable anti-tippers

⚠ WARNING

Refer to Owner's Manual for proper anti-tipper setting.

1085379

⚠ WARNING

DO NOT OPERATE WITHOUT THE ANTI-TIP TUBES INSTALLED.

REV. 5/98 P/N 60106X144

TYPICAL PRODUCT PARAMETERS

TRACER EX2	
OVERALL WIDTH PERMANENT ARM: REMOVABLE ARM:	23¼, 25¼, 27¼ inches 24¼, 26¼, 28¼ inches
OVERALL DEPTH (WITH RIGGINGS)	31-7/8-inches
SEAT WIDTH	16, 18 or 20 inches
SEAT DEPTH SA FRAME: FF FRAME:	16 inches 16 inches
SEAT-TO-FLOOR (WITH 24-INCH WHEELS) ADULT: (SA FRAME): ADULT: (FF FRAME): HEMI: (SA FRAME):	19-1/2 inches 21 inches 17-1/2/ inches
BACK STYLE	Fixed
BACK HEIGHT	16 inches
ARM STYLES	Fixed or Adjustable Height; Desk or Full Length; Permanent or Removable
FRONT RIGGINGS	Swingaways Footrests, Elevating Legrests, (Not Available On FF Frame)
REAR AXLE	Permanent
REAR WHEELS	24-inch Composite or Urethane
HANDRIMS	Composite*
WHEEL LOCKS	Push to Lock* (Adult), Pull to Lock* (Hemi)
CASTER SIZE	8x1-inch Solid Rubber
UPHOLSTERY	Vinyl - Midnight Blue
FRAME COLORS	Chrome* and colors
WEIGHT*** (APPROX.) PERMANENT ARM: REMOVABLE ARM:	36 pounds (SA Frame), 37 pounds (FF Frame) 36 pounds (SA Frame)
SHIPPING WEIGHT*** (APPROX.) PERMANENT ARM: REMOVABLE ARM:	45-1/2 pounds (SA Frame), 46-1/2 pounds (FF Frame) 45-1/2 pounds (SA Frame)
WEIGHT LIMIT	250 lbs (114 kg)

*NOTE: These options are standard for this model.

**NOTE: The seat-to-floor heights are based on urethane tires. These heights can vary +/- ¼-inch due to tire wear and manufacturing tolerances.

***NOTE: Weights based on 18-inch wide wheelchair without front riggings. Weights will vary depending on how wheelchair is equipped.

SECTION I—GENERAL GUIDELINES

⚠ WARNING

SECTION I - GENERAL GUIDELINES contains important information for the safe operation and use of this product. **DO NOT** use this product or any available optional equipment without first completely reading and understanding these instructions and any additional instructional material such as owner's manuals, service manuals or instruction sheets supplied with this product or optional equipment. If you are unable to understand the **Warnings, Cautions or Instructions**, contact a healthcare professional, dealer or technical personnel before attempting to use this equipment. Otherwise, injury or damage may occur.

Stability - All Models

The size/position of the front casters, size/position of the rear wheels, use of anti-tipper model, as well as the user condition directly relate to the stability of the wheelchair. Any change to one or any combination of the six may cause the wheelchair to decrease in stability. These adjustments must be performed by a qualified technician.

<i>NOTE: When changes to the left hand column occur, follow across the chart and refer to the procedure that is checked (✓) to maintain the proper stability, safety and handling of the wheelchair.</i>	CASTER SIZE	CASTER POSITION	WHEEL SIZE	WHEEL POSITION	ANTI-TIPPERS	USER CONDITION
CASTER SIZE	•	X	X	X	X	X
CASTER POSITION	X	•	X	X	X	X
WHEEL SIZE	X	X	•	X	X	X
ANTI-TIPPERS	X	X	X	•	X	X
USER CONDITION	X	X	X	X	X	•

The various seat-to-floor heights require specific settings depending on rear wheel size, rear wheel position and front caster size/position. These adjustments **MUST** be performed by a qualified technician.

Anti-Tippers

Anti-tippers are specific to the different angles and/or seat-to-floor heights. Refer to the charts in Installing/Adjusting Anti-tippers on page 46 for correct usage and adjustment. If these requirements cannot be achieved, **DO NOT** use the wheelchair. Contact a qualified technician. If changing the seat-to-floor height, the correct anti-tippers **MUST** be used to maintain a 1½ to 2-inch ground clearance.

Anti-tippers **MUST** be attached at all times. Inasmuch as the anti-tippers are an option for on this wheelchair (you may order with or without the anti-tippers), Invacare strongly recommends ordering the anti-tippers as a safeguard for the wheelchair user.

ALWAYS use anti-tippers. When outdoors on wet, soft ground or on gravel surfaces, anti tippers may not provide the same level of protection against tipover. Extra caution must be observed when traversing such surfaces.

Operating Information

After any adjustments, repair or service and before use, make sure all attaching hardware is tightened securely - otherwise injury or damage may result.

Unless otherwise noted, all service and adjustment should be performed while the wheelchair is unoccupied.

To determine and establish your particular safety limits, practice bending, reaching and transferring activities in several combinations in the presence of a qualified healthcare professional before attempting active use of the wheelchair.

When cleaning rear cane or hand grip areas use only a clean towel lightly dampened with cool water. Verify that grips are dry prior to use. Use of soap or ammonia based cleaning solutions will result in the hand grips sliding off the cane assembly. Failure to observe this warning may result in injury to the user or bystanders.

If the wheelchair is exposed to extreme temperature (above 100°F or below 32°F), high humidity and/or becomes wet, prior to use, ensure that the handgrips do not twist on the handle. Otherwise, damage or injury may occur.

Avoid storing or using the wheelchair near open flame or combustible products. Serious injury or damage to property may result.

ALWAYS keep hands and fingers clear of moving parts to avoid injury.

DO NOT traverse, climb or go down ramps or slopes greater than 9°.

DO NOT attempt to move up or down an incline with a water, ice or oil film.

DO NOT operate on roads, streets or highways.

DO NOT attempt to ride over curbs or obstacles. Doing so may cause your wheelchair to tip over and cause bodily harm to you or damage to the wheelchair.

DO NOT attempt to reach objects if you have to move forward in the seat.

DO NOT attempt to reach objects if you have to pick them up from the floor by reaching down between your knees.

DO NOT lean over the top of the back upholstery to reach objects behind you, as this may cause the wheelchair to tip over.

DO NOT shift your weight or sitting position toward direction you are reaching as the wheelchair may tip over.

DO NOT attempt to stop a moving wheelchair with wheel locks. Wheel locks are not brakes.

DO NOT tip the wheelchair without assistance.

DO NOT use an escalator to move a wheelchair between floors. Serious bodily injury may occur.

Before attempting to transfer in or out of the wheelchair, every precaution should be taken to reduce the gap distance. Turn both casters parallel to the object you are transferring onto. When transferring to and from the wheelchair, ALWAYS engage both wheel locks.

DO NOT attempt to lift the wheelchair by any removable (detachable) parts. Lifting by means of any removable (detachable) parts of the wheelchair may result in injury to the user or damage to the wheelchair.

DO NOT stand on the frame of the wheelchair.

DO NOT use the footplate as a platform. When getting in or out of the wheelchair, make sure that the footplates are in the upward position.

ALWAYS wear your seat positioning strap. Inasmuch as the seat positioning strap is an option on this wheelchair (you may order with or without the seat positioning strap), Invacare strongly recommends ordering the seat positioning strap as an additional safeguard for the wheelchair user. The seat positioning strap is a positioning belt only. It is not designed for use as a safety device withstanding high stress loads such as auto or aircraft safety belts. If signs of wear appear, belt must be replaced immediately.

ALWAYS use the handrims for self-propulsion. Inasmuch as the handrims are an option on this wheelchair (you may order with or without the handrims), Invacare strongly recommends ordering the handrims as an additional safeguard for the wheelchair user.

Make sure detent balls of the quick-release pin are fully released before operating the wheelchair.

The detent balls MUST be protruding past the top of the seat plate assembly for a positive lock.

Keep detent balls clean.

Weight Training

Invacare does not recommend the use of its wheelchairs as a weight training apparatus. Invacare wheelchairs have not been designed or tested as a seat for any kind of weight training. If occupant uses said wheelchair as a weight training apparatus, Invacare shall not be liable for bodily injury or damage to the wheelchair and the warranty is void.

Weight Limitation

The Tracer EX2 wheelchair has a weight limitation of 250 lbs (114 kg).

SECTION 2—SAFETY/HANDLING OF WHEELCHAIRS

Safety/Handling of Wheelchairs

Safety and handling of the wheelchair require the close attention of the wheelchair user as well as the assistant. This manual points out the most common procedures and techniques involved in the safe operation and maintenance of the wheelchair. It is important to practice and master these safe techniques until you are comfortable in maneuvering around the frequently encountered architectural barriers.

Use this information only as a basic guide. The techniques that are discussed on the following pages have been used successfully by many.

Individual wheelchair users often develop skills to deal with daily living activities that may differ from those described in this manual. Invacare recognizes and encourages each individual to try what works best for him/her in overcoming architectural obstacles that they may encounter. However, all warnings and cautions given in this manual **MUST** be heeded. Techniques in this manual are a starting point for the new wheelchair user and assistant with “safety” as the most important consideration for all.

Stability and Balance

WARNING

ALWAYS wear your seat positioning strap. Inasmuch as the seat positioning strap is an option on this wheelchair (You may order with or without the seat positioning strap), Invacare strongly recommends ordering the seat positioning strap as an additional safeguard for the wheelchair user.

ALWAYS wear your seat positioning strap. Inasmuch as the seat positioning strap is an option on this wheelchair (you may order with or without the seat positioning strap), Invacare strongly recommends ordering the seat positioning strap as an additional safeguard for the wheelchair user. The seat positioning strap is a positioning belt only. It is not designed for use as a safety device withstanding high stress loads such as auto or aircraft safety belts. If signs of wear appear, belt **MUST be replaced immediately.**

To assure stability and proper operation of your wheelchair, you **MUST** maintain proper balance at all times. Your wheelchair has been designed to remain upright and stable during normal daily activities as long as you do not move beyond the center of gravity.

Virtually all activities which involve movement in the wheelchair have an effect on the center of gravity. Invacare recommends using seat/chest positioning straps for additional safety while involved in activities that shift your weight.

DO NOT lean forward out of the wheelchair any further than the length of the armrests. Make sure the casters are pointing in the forward position whenever you lean forward. This can be achieved by advancing the wheelchair and then reversing it in a straight line.

Coping With Everyday Obstacles

Coping with the irritation of everyday obstacles can be alleviated somewhat by learning how to manage your wheelchair. Keep in mind your center of gravity to maintain stability and balance.

A Note to Wheelchair Assistants

When assistance to the wheelchair user is required, remember to use good body mechanics. Keep your back straight and bend your knees whenever tipping the wheelchair or traversing curbs, or other impediments.

DO NOT attempt to lift the wheelchair by any removable (detachable) parts. Lifting by means of any removable (detachable) parts of the wheelchair may result in injury to the user or damage to the wheelchair.

If the wheelchair is exposed to extreme temperature (above 100°F or below 32°F), high humidity and/or becomes wet, prior to use, ensure handgrips do not twist on the wheelchair's handle - otherwise damage or injury may occur.

Also, be aware of detachable parts such as armrests or legrests. These must NEVER be used to move the wheelchair or as lifting supports, as they may be inadvertently released, resulting in possible injury to the user and/or assistant(s).

When learning a new assistance technique, have an experienced assistant help you before attempting it alone.

WARNING

DO NOT attempt to reach objects if you have to move forward in the seat or pick them up from the floor by reaching down between your knees.

The size/position of the front casters, size/position of the rear wheels, use of anti-tipper model, as well as the user condition directly relate to the stability of the wheelchair. Any change to one or any combination of the six may cause the wheelchair to decrease in stability. These adjustments MUST be performed by a qualified technician.

Many activities require the wheelchair owner to reach, bend and transfer in and out of the wheelchair. These movements will cause a change to the normal balance, the center of gravity, and the weight distribution of the wheelchair. To determine and establish your particular safety limits, practice bending, reaching and transferring activities in several combinations in the presence of a qualified healthcare professional before attempting active use of the wheelchair.

Proper positioning is essential for your safety. When reaching, leaning, or bending forward, it is important to use the front casters as a tool to maintain stability and balance.

Reaching, Leaning and Bending Forward

⚠ WARNING

DO NOT attempt to reach objects if you have to move forward in the seat or pick them up from the floor by reaching down between your knees.

NOTE: For this procedure, refer to FIGURE 2.1.

Position the front casters so that they are extended as far forward as possible and engage wheel locks.

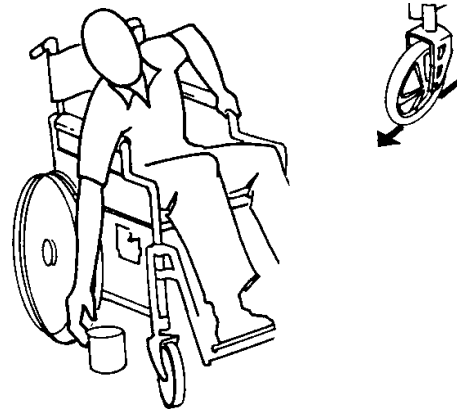

FIGURE 2.1 Reaching, Leaning and Bending Forward

Reaching and Leaning Backwards

⚠ WARNING

DO NOT lean over the top of the back upholstery to reach objects behind you, as this may cause the wheelchair to tip over.

NOTE: For this procedure, refer to FIGURE 2.2.

Position wheelchair as close as possible to the desired object. Point front casters forward to create the longest possible wheelbase. Reach back only as far as your arm will extend without changing your sitting position.

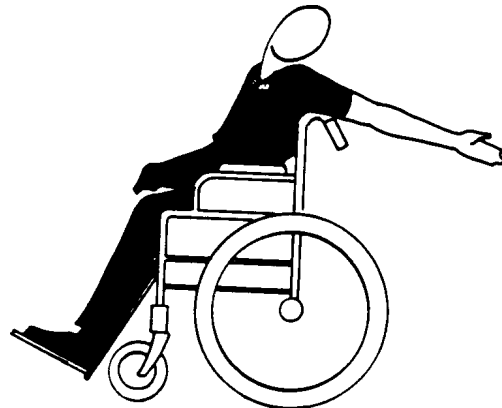

FIGURE 2.2 Reaching and Leaning Backwards

Tipping

⚠ WARNING

DO NOT tip the wheelchair without assistance.

When tipping the wheelchair, an assistant should grasp the back of the wheelchair on a non-removable (non-detachable) part. Inform the wheelchair occupant before tipping the wheelchair and remind him/her to lean back. Be sure the occupant's feet and hands are clear of all wheels and/or pinch points.

After mastering the techniques of tipping the wheelchair, use one of the following methods to tackle curbs, short stairs, etc.

Method 1 - Wheelchair With Step Tubes

NOTE: For this procedure, refer to FIGURE 2.3.

Place foot on the step tube and begin to tilt the wheelchair toward you. Apply a continuous downward motion until the balance point is achieved and the front casters clear the curb. At this point, the assistant will feel a difference in the weight distribution.

⚠ WARNING

When lowering the front casters of the wheelchair, DO NOT let the wheelchair drop the last few inches to the ground. This could result in injury to the occupant and/or damage to the wheelchair.

Roll the wheelchair forward and slowly lower the front of the wheelchair in one continuous movement onto the sidewalk. Push the wheelchair forward until the rear wheels roll up and over the curb.

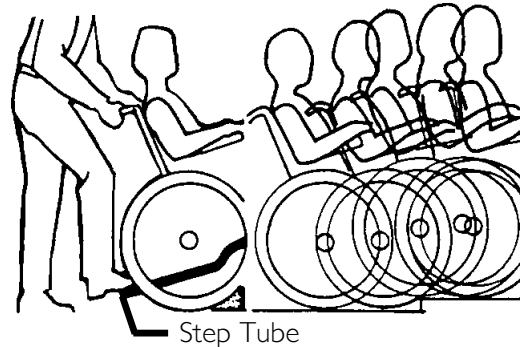

FIGURE 2.3 Method 1 - Wheelchair With Step Tubes

Method 2 - Wheelchair Without Step Tubes

⚠ WARNING

ALWAYS check hand grips for looseness before using the wheelchair. If loose and/or worn, replace immediately.

NOTE: For this procedure, refer to FIGURE 2.4.

This method requires two assistants. The second assistant should be positioned at the front of the wheelchair lifting upward on a non-removable (non-detachable) part of the wheelchair frame when lifting the wheelchair and stabilizing the wheelchair when the wheelchair is being lowered to the ground.

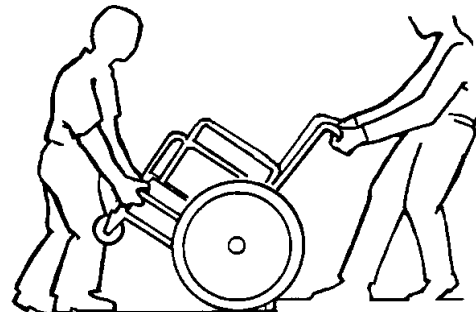

FIGURE 2.4 Method 2 - Wheelchair Without Step Tubes

The first assistant should stand on the sidewalk and turn the wheelchair so that the rear wheels are against the curb. Turn the anti-tippers so the anti-tip wheels are pointing up. The wheelchair should be tilted back to the balance point and, in one continuous upward movement, the rear wheels should be pulled up and over the curb. DO NOT return the front casters to the ground until the wheelchair has been pulled backward far enough for the front casters to clear the edge of the curb.

⚠ WARNING

When lowering the front casters of the wheelchair, DO NOT let the wheelchair drop the last few inches to the ground. This could result in injury to the occupant and/or damage to the wheelchair.

Roll the wheelchair backward and slowly lower the wheelchair in one continuous movement. Turn the anti-tippers so the anti-tip wheels are facing down.

Stairways

⚠ WARNING

ALWAYS wear your seat positioning strap. Inasmuch as the seat positioning strap is an option on this wheelchair (you may order with or without the seat positioning strap), Invacare strongly recommends ordering the seat positioning strap as an additional safeguard for the wheelchair user. The seat positioning strap is a positioning belt only. It is not designed for use as a safety device withstanding high stress loads such as auto or aircraft safety belts. If signs of wear appear, belt **MUST** be replaced immediately.

DO NOT attempt to lift a wheelchair by lifting on any removable (detachable) parts. Lifting by means of any removable (detachable) parts of the wheelchair may result in injury to the user or damage to the wheelchair.

ALWAYS check hand grips for looseness before using the wheelchair. If loose and/or worn, replace immediately.

Extreme caution is advised when it is necessary to move an occupied wheelchair up or down the stairs. Invacare recommends that, if possible, the user be removed from the wheelchair prior to moving. Invacare recommends using two assistants and making thorough preparations. Make sure to use only secure, non-detachable parts for hand-held supports.

NOTE: For this procedure, refer to FIGURE 2.5.

Follow this procedure for moving the wheelchair between floors when an elevator is not available:

1. If necessary, rotate the anti-tippers so the wheels are facing up.
2. After the wheelchair has been tilted back to the balance point, one assistant (in the rear) backs the wheelchair up against the first step, while securely grasping a non-removable (non-detachable) part of the wheelchair for leverage.
3. The second assistant, with a firm hold on a non-detachable part of the framework, lifts the wheelchair up and over the stair and steadies the wheelchair as the first assistant places one foot on the next stair and repeats STEP 1.
4. The wheelchair should not be lowered until the last stair has been negotiated and the wheelchair has been rolled away from the stairway.
5. If necessary, rotate the anti-tippers so the wheels are facing down.

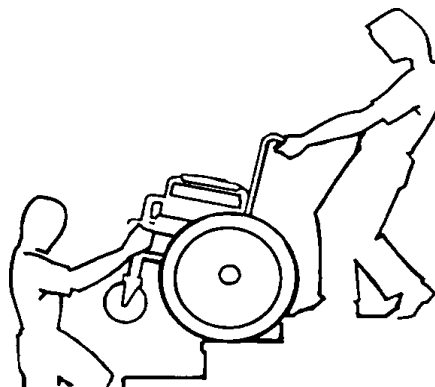

FIGURE 2.5 Stairways

Escalators

⚠ WARNING

DO NOT use an escalator to move a wheelchair between floors. Serious bodily injury may occur.

Transferring To and From Other Seats

⚠ WARNING

Before attempting to transfer in or out of the wheelchair, every precaution should be taken to reduce the gap distance. Turn both casters parallel to the object you are transferring onto. Also be certain the wheel locks are engaged to help prevent the wheels from moving.

CAUTION

When transferring, position yourself as far back as possible in the seat. This will help prevent damaged upholstery and the possibility of the wheelchair tipping forward.

NOTE: For this procedure, refer to FIGURE 2.6.

NOTE: This activity may be performed independently provided you have adequate mobility and upper body strength.

Position the wheelchair as close as possible alongside the seat to which you are transferring, with the front casters pointing parallel to it. Remove or flip up the armrest. Engage wheel locks. Swing away or remove front rigging. Shift body weight into seat with transfer.

During independent transfer, little or no seat platform will be beneath you. Use a transfer board if at all possible.



FIGURE 2.6 Transferring To and From Other Seats

Unfolding and Folding Wheelchair

⚠ WARNING

ALWAYS keep hands and fingers clear of moving parts to avoid injury.

DO NOT place hand or fingers on the underside of the seat frame rail when opening or closing the wheelchair.

DO NOT sit or transfer into the wheelchair unless it is fully open and the seat frame rails are fully seated into the side frame H-blocks.

Invacare recommends that a non-folding device be installed to keep the wheelchair from being folded when left unoccupied in a public place.

Unfolding

NOTE: For this procedure, refer to FIGURE 2.7 on page 23.

1. Tilt the wheelchair toward you (raising the opposite wheel and caster off the ground/floor).
2. Place your hand on the top of the seat rail closest to you where the seat upholstery is attached.
3. Point your fingers and thumb to the inside of the wheelchair.
4. Press downward on the top of the seat rail until the wheelchair is fully open and the seat rails are fully seated in the H-blocks.
5. Engage both wheel locks, open the footrest/legrest for clearance and transfer into the wheelchair. Refer to [Transferring To and From Other Seats](#) on page 21.

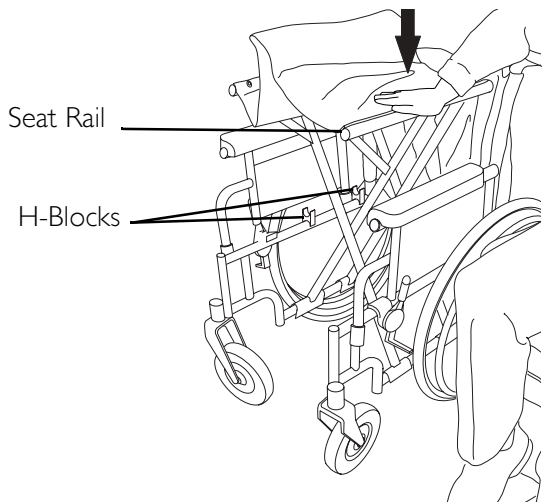

NOTE: DO NOT wrap thumb or fingers under the seat rail. Point fingers and thumb to the inside of the wheelchair.

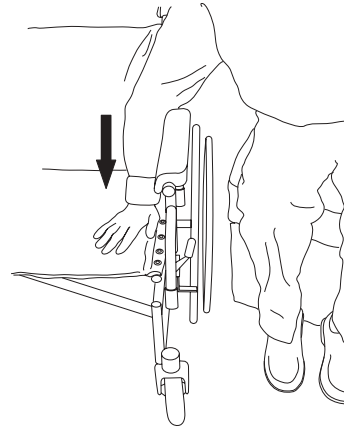

NOTE: Press down on the seat rail and the seat upholstery with the entire hand. DO NOT place any part of the hand under the seat rail.

FIGURE 2.7 Unfolding

Folding Wheelchair

NOTE: For this procedure, refer to FIGURE 2.8.

1. Swing footrest/legrest in locked position to the front of the wheelchair.
2. Pivot footplates upward to vertical position.
3. With both hands, grasp the middle of the seat upholstery at the front and back edge and lift up.

CAUTION

DO NOT allow upholstery to hang between the cross braces.

4. Place excess seat upholstery over the armrest.

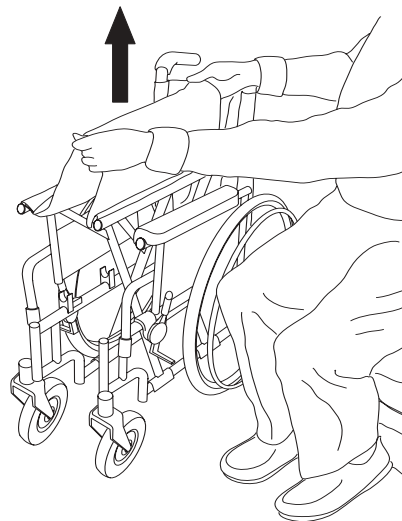

FIGURE 2.8 Folding Wheelchair

Folding Hammock or Sling Seat Models.

NOTE: For this procedure, refer to FIGURE 2.9.

1. Swing footrest/legrest and calfpads in locked position to the front of the wheelchair.
2. Pivot footplates upward to vertical position.
3. With both hands, grasp the middle of the seat upholstery at the front and back edge and lift up.
4. Continue to close the wheelchair by grasping the armrest furthest from you and pulling the armrest towards you.

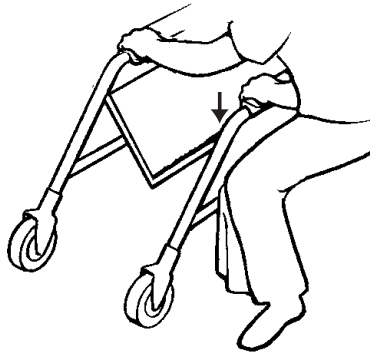

FIGURE 2.9 Folding Hammock or Sling Seat Models.

SECTION 3—SAFETY INSPECTION/TROUBLESHOOTING

NOTE: Every six months or as necessary, take your wheelchair to a qualified technician for a thorough inspection and servicing. Regular cleaning will reveal loose or worn parts and enhance the smooth operation of your wheelchair. To operate properly and safely, your wheelchair must be cared for just like any other vehicle. Routine maintenance will extend the life and efficiency of your wheelchair.

Safety Inspection Checklist

Initial adjustments should be made to suit your personal body structure and preference. Thereafter follow these maintenance procedures:

Inspect/Adjust Initially

- Ensure that the wheelchair rolls straight (no excessive drag or pull to one side).
- Inspect for loose or missing hardware on frame and crossbraces.
- Inspect for bent frame or crossbraces.
- Check that the wheel locks do not interfere with tires when rolling.
- Check that the wheel lock pivot points are free of wear and looseness.
- Check that the wheel locks are easy to engage.
- Ensure that the wheel locks prevent the wheelchair from moving when engaged.
- Inspect the seat and back for rips and sagging.
- Inspect the seat and back for loose or broken hardware.
- Inspect the back cane hand grips for wear/looseness/deterioration.
- Inspect seat positioning strap for any signs of wear. Ensure buckle latches. Verify hardware that attaches strap to frame is secure and undamaged. Replace if necessary.
- Inspect tires for flat spots and wear.
- Check pneumatic tires for proper inflation.

CAUTION

As with any vehicle, check the wheels and tires periodically for cracks and wear. Replace if damaged.

- If equipped, check that quick-release axles lock properly. Lubricate if necessary.
- Check that there is no excessive side movement or binding in the rear wheels when lifted and spun.
- Inspect rear wheels for cracked, bent or broken spokes.

- Ensure all spokes are uniformly tight.
- Inspect handrims for signs of rough edges or peeling.
- Inspect axle assembly for proper tension by spinning caster. Caster should come to a gradual stop.
- Adjust front casters/forks bearing system if wheel wobbles noticeably or binds to a stop.
- Ensure wheel bearings are clean and free of moisture.
- Check headtube locknuts for tightness.
- Inspect casters for cracks and wear.
- Inspect front casters for cracked, bent or broken spokes.
- Ensure that casters are free of debris.
- Clean upholstery and armrests.
- Check that all labels are present and legible. Replace if necessary.

Inspect/Adjust Weekly

- Ensure that the wheel locks prevent the wheelchair from moving when engaged.
- Inspect tires for flat spots and wear.
- Check pneumatic tires for proper inflation.
- If equipped, check that quick-release axles lock properly. Lubricate if necessary.
- Inspect rear wheels for cracked, bent or broken spokes.
- Ensure all spokes are uniformly tight.
- Inspect axle assembly for proper tension by spinning caster. Caster should come to a gradual stop.
- Inspect front caster for cracked, bent or broken spokes.
- Ensure that casters are free of debris.

Inspect/Adjust Monthly

- Ensure that the wheelchair rolls straight (no excessive drag or pull to one side).
- Check that the wheel locks do not interfere with tires when rolling.
- Check that the wheel lock pivot points are free of wear and looseness.
- Inspect seat and back for loose or broken hardware.
- Inspect seat positioning strap for any signs of wear. Ensure buckle latches. Verify hardware that attaches strap to frame is secure and undamaged. Replace if necessary.
- Inspect back cane hand grips for wear/looseness/deterioration.
- Adjust front casters/forks bearing system if wheel wobbles noticeably or binds to a stop.

- Ensure wheel bearings are clean and free of moisture.
- Check headtube locknuts for tightness.

Inspect/Adjust Periodically

- Inspect frame and crossbraces for loose or missing hardware.
- Inspect for bent frame or crossbraces.
- Check that wheel locks are easy to engage.
- Inspect seat and backs for rips and sagging.
- Check that there is no excessive side movement or binding in the rear wheels when lifted and spun.
- Inspect handrims for signs of rough edges or peeling.
- Adjust front casters/forks bearing system if wheel wobbles noticeably or binds to a stop.
- Ensure wheel bearings are clean and free of moisture.
- Inspect casters for cracks and wear.
- Ensure that casters are free of debris.
- Clean upholstery and armrests.
- Check that all labels are present and legible. Replace if necessary.

Troubleshooting

Chair Veers Right/Left	Chair 3 Wheels	Sluggish Turn or Performance	Casters Flutter	Squeaks and Rattles	Looseness in Chair	Solutions
X	X	X	X			Check tires for correct and equal pressure
		X	X	X	X	Check for loose nuts and bolts.
X	X		X			Check caster headtube angle.
X	X					Check that rear wheels are equally spaced away from seat frame.

Maintenance

Maintenance Safety Precautions

⚠ WARNING

After any adjustments, repair or service and before use, make sure all attaching hardware is tightened securely. Otherwise injury or damage may result.

CAUTION

DO NOT overtighten hardware attaching to the frame. This could cause damage to the frame tubing.

Suggested Maintenance Procedures

1. Before using your wheelchair, make sure all nuts and bolts are tight. Check all parts for damage or wear and replace. Check all parts for proper adjustment.
-

CAUTION

As with any vehicle, the rear wheels, casters and tires should be checked periodically for cracks and wear, and should be replaced if damaged.

2. The rear wheels, casters and tires should be checked periodically for cracks and wear, and should be replaced by a qualified technician if damaged.

NOTE: Tire wear is excessive if:

- *Pneumatic Tires - there is missing tread or the tires are bald.*
- *Urethane Tires - there are cuts, surface defects or the tires are loose on the rims.*
- *Rubber Tires - 30% or more of the tire has worn away.*

NOTE: Invacare recommends that tires and casters be replaced every five years.

3. Periodically adjust wheel locks in correlation to tire wear. Refer to Adjusting Patient Operated Wheel Locks on page 49.
 4. Periodically check handrims to ensure they are secured to the rear wheels. If loose, have them tightened by a qualified technician.
 5. Periodically check caster wheel bearings to make sure they are clean and free from moisture. Use a Teflon™ lubricant if necessary.
-

⚠ WARNING

When cleaning rear cane or hand grip areas use only a clean towel lightly dampened with cool water. Verify that grips are dry prior to use. Use of soap or ammonia based cleaning solutions will result in the hand grips sliding off the cane assembly. Failure to observe this warning may result in injury to the user or bystanders.

6. Hand grips should be checked monthly for wear/looseness/deterioration. Clean if desired. Replace if looseness or deterioration is found.
 7. Check upholstery for sagging, rips or tears.
-

SECTION 4—FRONT RIGGINGS

⚠ WARNING

After any adjustments, repair or service and before use, make sure all attaching hardware is tightened securely. Otherwise injury or damage may occur.

Installing/Removing Front Riggings

NOTE: For this procedure, refer to FIGURE 4.1.

Installing

1. Turn the front rigging assembly to the side (open front rigging is perpendicular to wheelchair).
2. Install the hinge plates on the front rigging assembly onto the hinge pins on the wheelchair frame.
3. Push the front rigging assembly towards the inside of the wheelchair until it locks into place.

NOTE: The footplate will be on the inside of the wheelchair when locked in place.

4. Repeat this procedure for the other front rigging assembly.
5. To release the front rigging, push the front rigging release lever inward, rotate front rigging outward.

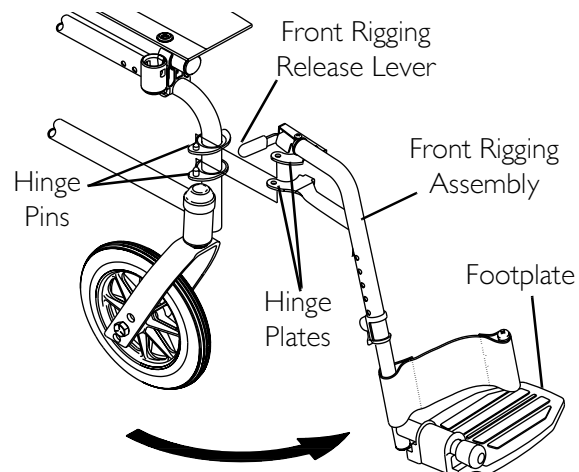

NOTE: Swingaway footrest shown.

FIGURE 4.1 Installing/Removing Front Riggings

Removing

1. Push the front rigging release lever inward
2. Rotate swingaway front rigging assembly outward.
3. Lift the swingaway front rigging assembly off the hinge pins.

Adjusting Footplate Height

Spring Button

NOTE: For this procedure, refer to FIGURE 4.2.

NOTE: This procedure applies to the swingaway front riggings and swingaway elevating legrest.

1. Remove the front rigging assembly. Refer to [Installing/Removing Front Riggings](#) on page 29.

NOTE: Lay the front rigging assembly on a flat surface to simplify this procedure.

2. Pull the cam lock lever up to unlocked position.

NOTE: The elevating legrest has two sets of release buttons, one set above the other. Each set will be visible one at a time allowing finer footplate height adjustment.

3. Push in the release buttons and reposition the footplate assembly to the desired height.
4. Ensure that the release buttons fully protrude from holes on both sides of the front rigging support.
5. Rotate cam lock lever down to locked position.
6. Repeat this procedure for the other footplate, if necessary.
7. Reinstall the swingaway front rigging assembly. Refer to [Installing/Removing Front Riggings](#) on page 29.

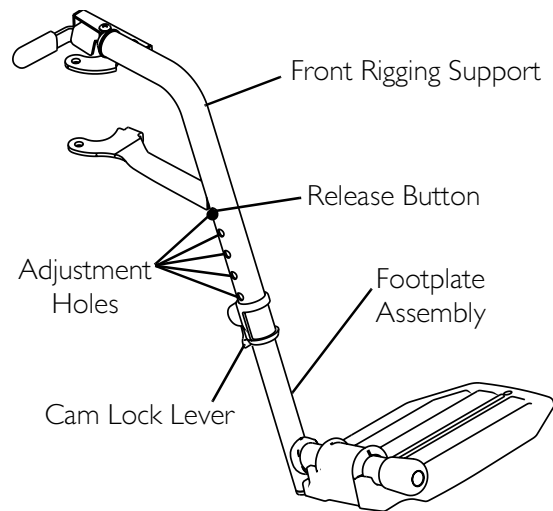

NOTE: Swingaway footrest shown.

FIGURE 4.2 Spring Button

Bolt-In-Place

NOTE: For this procedure, refer to FIGURE 4.3 on page 31.

NOTE: This procedure applies to the swingaway footrests and swingaway elevating legrest.

1. Remove the swingaway front rigging. Refer to [Installing/Removing Front Riggings](#) on page 29.

NOTE: Lay the front rigging assembly on a flat surface to simplify this procedure.

2. Pull the cam lock lever up to the unlocked position.
3. Using a screw driver to hold the threaded rivet in position, remove the button head screw from the threaded rivet.
4. Remove the threaded rivet and button head screw securing the footplate assembly to the front rigging support.

5. Adjust the footplate assembly height by aligning the desired adjustment holes in the upper front rigging support and lower footplate assembly.
6. From the outside of the swingaway front rigging, insert the threaded rivet through both the front rigging support and the footplate assembly.
7. From the inside of the swingaway front rigging, insert the button head screw through the appropriate adjustment hole and thread into the threaded rivet.
8. Using a screwdriver to hold the threaded rivet in position, securely tighten the button head screw. Torque to 32 in-lbs.
9. Rotate cam lock lever down to locked position.
10. Repeat STEPS 1-9 to adjust the remaining footrest.

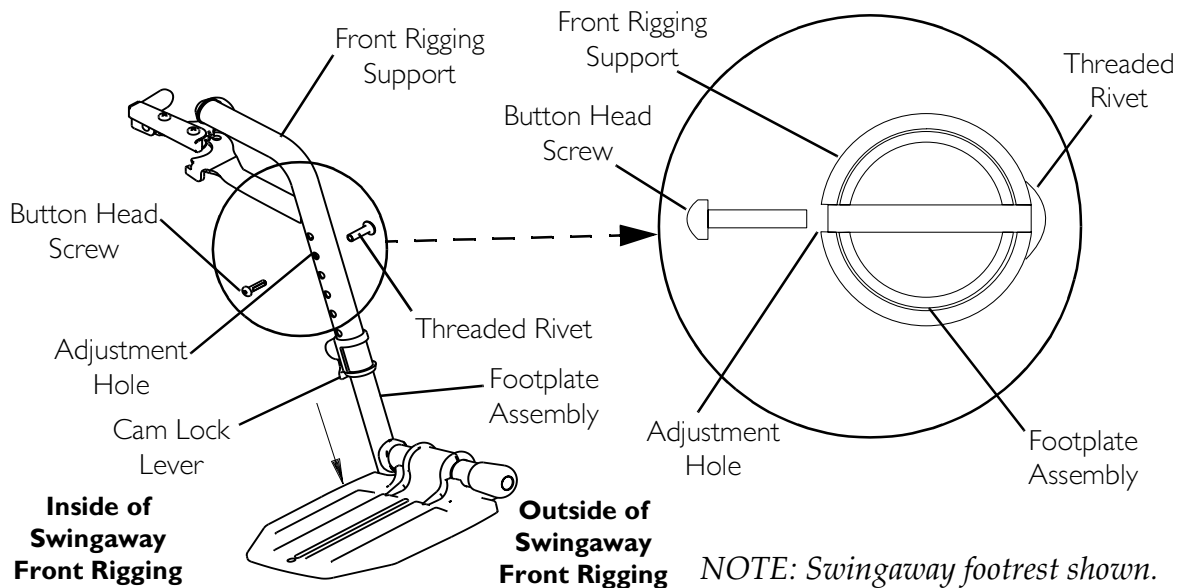

FIGURE 4.3 Bolt-In-Place

Fixed Frame

NOTE: For this procedure, refer to FIGURE 4.4

1. Remove impact guards and/or calf strap, if necessary.
2. Loosen, but do not remove the bolt and locknut that secure the lower footrest assembly to the upper footrest support.
3. Reposition the lower footrest assembly to the desired height.
4. Securely tighten the bolt and locknut.
5. Repeat this procedure for the other footrest, if necessary.
6. Replace impact guards and/or calf strap, if necessary.

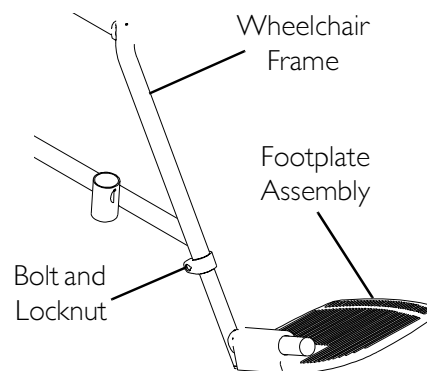

FIGURE 4.4 Fixed Frame

Raising/Lowering Elevating Legrest Assembly

⚠ WARNING

Ensure hands and fingers are clear of elevating legrest mechanism before pushing release lever to lower the elevating legrest. Otherwise injury may occur due to pinch points.

The wheelchair user's leg **MUST** be supported by an assistant before attempting to lower legrest.

NOTE: For this procedure, refer to FIGURE 4.5.

1. To raise the elevating legrest, the assistant should hold the support tube and raise the elevating legrest until the desired height is obtained.
2. To lower the elevating legrest, perform the following:
 - A. Support user leg with one hand.
 - B. Push release lever downward with other hand.
 - C. Gently, lower user leg down and rest against the legrest.

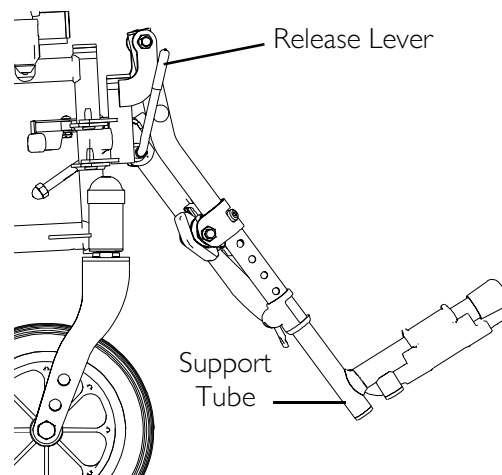

FIGURE 4.5 Raising/Lowering Elevating Legrest Assembly

Installing Impact Guards/Calf Strap

NOTE: For this procedure, refer to FIGURE 4.6.

1. Remove impact guard/calf strap from packaged container if not already secured to the footrest.
2. Secure one impact guard to the each footrest.

NOTE: Ensure the upper portion of the impact guard is between the two horizontal supports of the footrest.

3. Secure one side of the calf strap around each footrest (with the impact guards attached, if present).

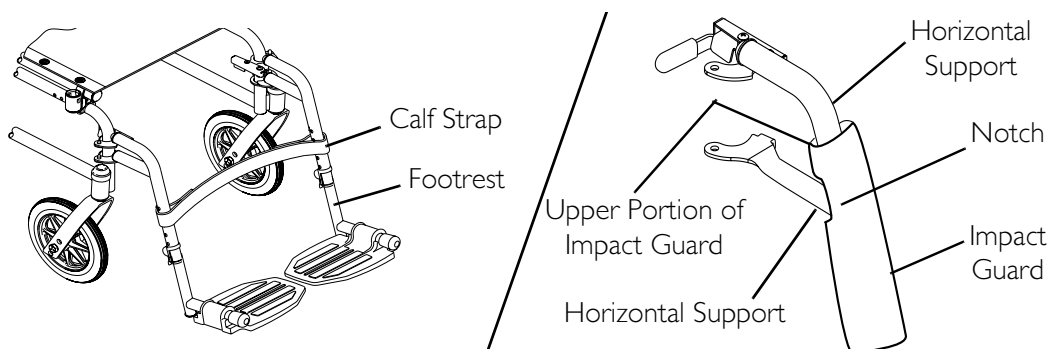

FIGURE 4.6 Installing Impact Guards/Calf Strap

Replacing Heel Loop

NOTE: For this procedure, refer to FIGURE 4.7 on page 34.

1. Pull the cam lock lever up to unlocked position.
2. Perform one of the following as shown in Detail "A".
 - Footplates with Spring Buttons: Push in the release buttons and remove the footplate assembly from the front rigging support.
 - Bolt-In-Place Footplates:
 - i. Using a screw driver to hold the threaded rivet in position, remove the button head screw from the threaded rivet.
 - ii. Remove the threaded rivet and button head screw securing the footplate assembly to the front rigging support.
3. Remove the mounting screw, spacer and locknut that secure the heel loop to the footplate.
4. Remove existing heel loop from slide tube.
5. Install new heel loop onto slide tube.
6. Install the mounting screw, spacer and locknut to secure the heel loop to the footplate. Tighten until the spacer is secure.
7. Insert the lower footrest assembly into the upper footrest assembly to desired height.
8. Perform one of the following as shown in Detail "A":
 - Footplates With Spring Buttons: Ensure that the release buttons fully protrude from holes on both sides of the upper footrest support.
 - Bolt-In-Place Footplates:
 - i. From the outside of the swingaway front rigging, insert the threaded rivet through both the front rigging support and the footplate assembly.
 - ii. From the inside of the swingaway front rigging, insert the button head screw through the appropriate adjustment hole and thread into the threaded rivet.
 - iii. Using a screwdriver to hold the threaded rivet in position, securely tighten the button head screw. Torque to 32 in-lbs.
9. Rotate cam lock lever down to locked position.

DETAIL "A"

Footplates with Spring Buttons

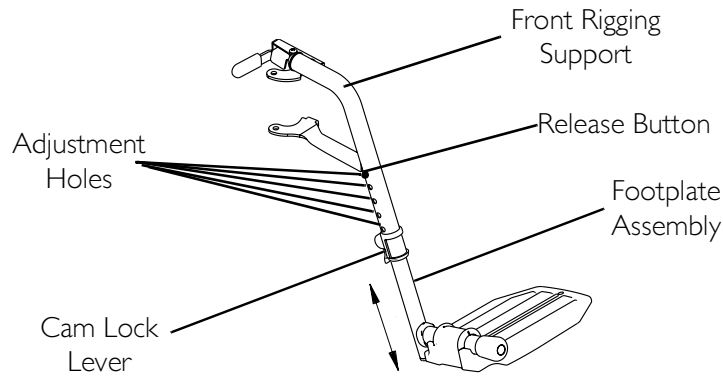

NOTE: Swingaway footrest shown.

Bolt-in-Place Footplates

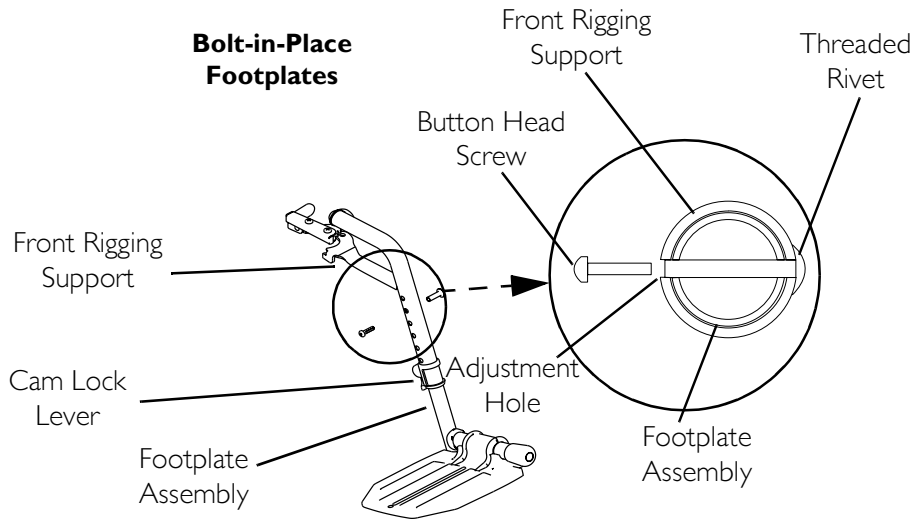

Inside of Swingaway Front Rigging

Outside of Swingaway Front Rigging

NOTE: Swingaway footrest shown.

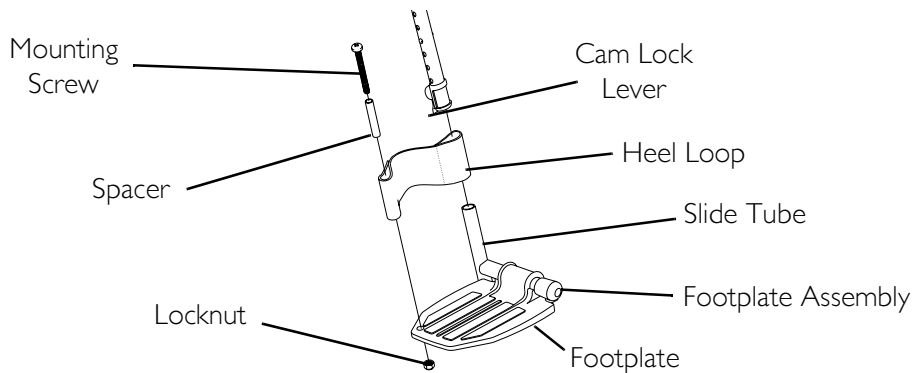

FIGURE 4.7 Replacing Heel Loop

SECTION 5—ARMS

⚠ WARNING

After any adjustments, repair or service and before use, make sure all attaching hardware is tightened securely. Otherwise injury or damage may occur.

Adjusting Armrest Height

⚠ WARNING

Make sure the height adjustment lever is in the locked position before using the wheelchair.

NOTE: For this procedure, refer to FIGURE 5.1.

1. Unlock the armrest by flipping the height adjustment lever on the top front of the armrest to the up (horizontal) position.
2. Adjust armrest to one of five positions.

NOTE: Height adjustment lever MUST be in the unlocked position when placing armrest into the arm assembly.

3. Lock the armrest by pressing the height adjustment lever into the down (vertical) position when the desired armrest height is achieved.
4. Repeat STEPS 1-3 for other armrest.

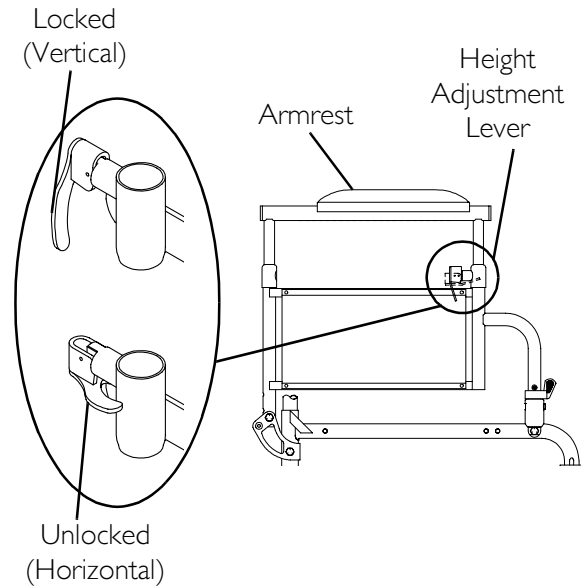

FIGURE 5.1 Adjusting Armrest Height

Removing/Installing Armrests

⚠ WARNING

Make sure the armrest release lever is in the locked position before using the wheelchair.

NOTE: For this procedure, refer to FIGURE 5.2.

Removing Armrest

1. Push down on armrest to ensure it is fully seated in front and rear sockets.

NOTE: STEP 1 prevents the release buttons from hanging up on the sockets during removal.

2. Unlock the rear armrest by rotating the armrest release lever towards the inside of the wheelchair.
3. Press in the armrest release button at the front of the armrest.
4. While pressing in the armrest release button, remove the armrest from the arm sockets by pulling straight up.

Installing Armrest

NOTE: Rear armrest release lever must be in the unlocked position when installing the armrest.

1. Position the armrest just above the front and rear arm sockets.
2. Push arm down evenly at the front and rear until the front armrest release button snaps into the front arm socket.
3. Lock rear armrest by turning the armrest release lever towards the outside of the wheelchair.
4. Ensure armrest is locked securely in the arm sockets by gently lifting up. If not locked, repeat STEPS 1-3.

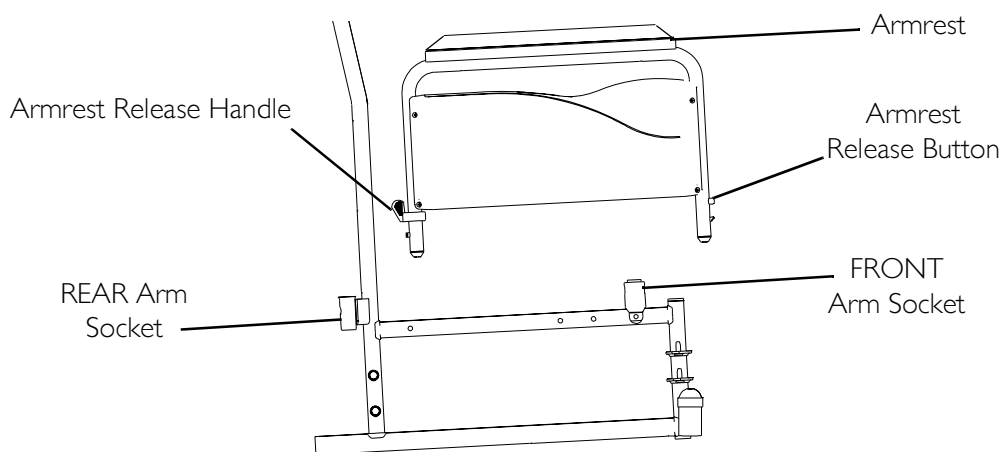

FIGURE 5.2 Removing/Installing Armrests

SECTION 6—SEAT AND BACK

⚠ WARNING

After any adjustments, repair or service and before use, make sure all attaching hardware is tightened securely. Otherwise injury or damage may occur.

After ANY adjustments, repair or service and BEFORE use, make sure all attaching hardware is tightened securely - otherwise injury or damage may occur.

Replacing Back Upholstery

NOTE: For this procedure, refer to FIGURE 6.1.

1. Remove the eight mounting screws and washers that secure the existing back upholstery to the back canes.
2. Remove existing back upholstery from the back canes.
3. Securely tighten the new back upholstery to the back canes with the phillips screws and washers. The following chart determines the number of mounting screws for each seat depth.

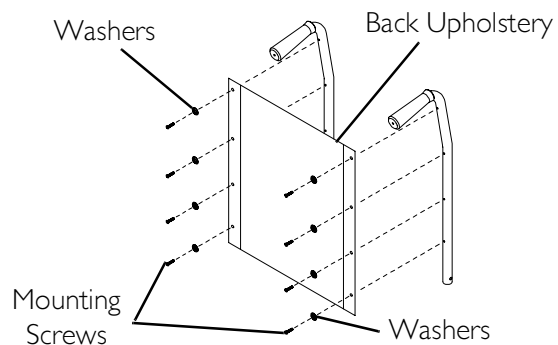

FIGURE 6.1 Replacing Back Upholstery

Replacing Seat Upholstery

NOTE: For this procedure, refer to FIGURE 6.2.

1. Remove the eight phillips screws and washers that secure the existing seat upholstery to the crossbraces.
2. Remove the existing seat upholstery from the crossbraces.
3. Ensure positioning of seat positioning strap (if used). Refer to [Installing the Seat Positioning Strap](#) on page 54.
4. Install new seat upholstery by reversing STEPS 1-2.

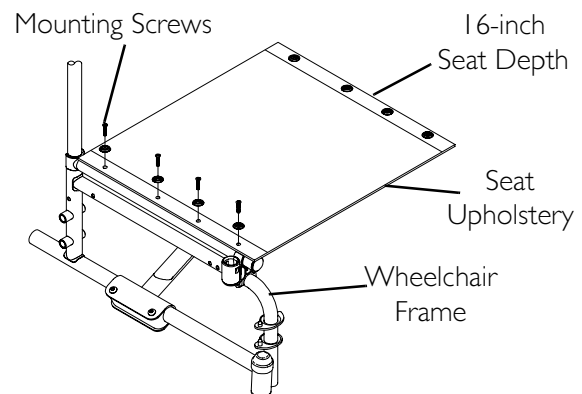

FIGURE 6.2 Replacing Seat Upholstery

Adjusting the Seat Width

Swingaway Front Riggings

NOTE: For this procedure, refer to FIGURE 6.3 on page 38 and FIGURE 6.4 on page 39.

NOTE: When adjusting the seat width of the wheelchair, the back and seat upholstery MUST be changed. If applicable, the headrest pillow and headrest upholstery MUST be changed as well.

1. Remove the existing back and seat upholstery from the wheelchair. Refer to Replacing Back Upholstery on page 37 and Replacing Seat Upholstery on page 37.
2. Remove the four button screws and locknuts that secure the two pivot links to the wheelchair frame and crossbraces.
3. Remove the two button screws, locknuts and crossbrace saddle that secures the bottom of the crossbrace to the wheelchair frame. Repeat for other crossbrace.
4. Remove the hex screw, coved washers, washers and locknut that secure the two crossbraces together. See Detail "B".

NOTE: Note the orientation of the coved washers, washers and locknut for assembling the new crossbraces. See Detail "B".

5. Assemble the two new crossbraces together with the existing hex screw, coved washers, washers and locknut. Securely tighten. Refer to Detail "B" for hardware orientation.
6. Determine the correct pivot link and mounting hole to use with the desired seat width. See chart below.
7. Secure the pivot links to the crossbraces and wheelchair frame with the four button screws and locknuts. Securely tighten.

NOTE: Position crossbrace saddle on wheelchair frame using the washer on the underside of the wheelchair frame as a reference. See Detail "A" for proper positioning of the crossbrace saddle.

8. Reinstall the two button screws, locknuts and crossbrace saddle that secures the bottom of the new crossbrace to the wheelchair frame. Refer to Detail "B" for hardware orientation. Repeat for opposite crossbrace. Securely tighten.
9. Install the new back and seat upholstery onto the wheelchair. Refer to Replacing Back Upholstery on page 37 and Replacing Seat Upholstery on page 37.

SEAT WIDTH	PIVOT LINK
16 - INCH 18 - INCH	
20 - INCH 22 - INCH	

FIGURE 6.3 Adjusting the Seat Width - Swingaway Front Riggings

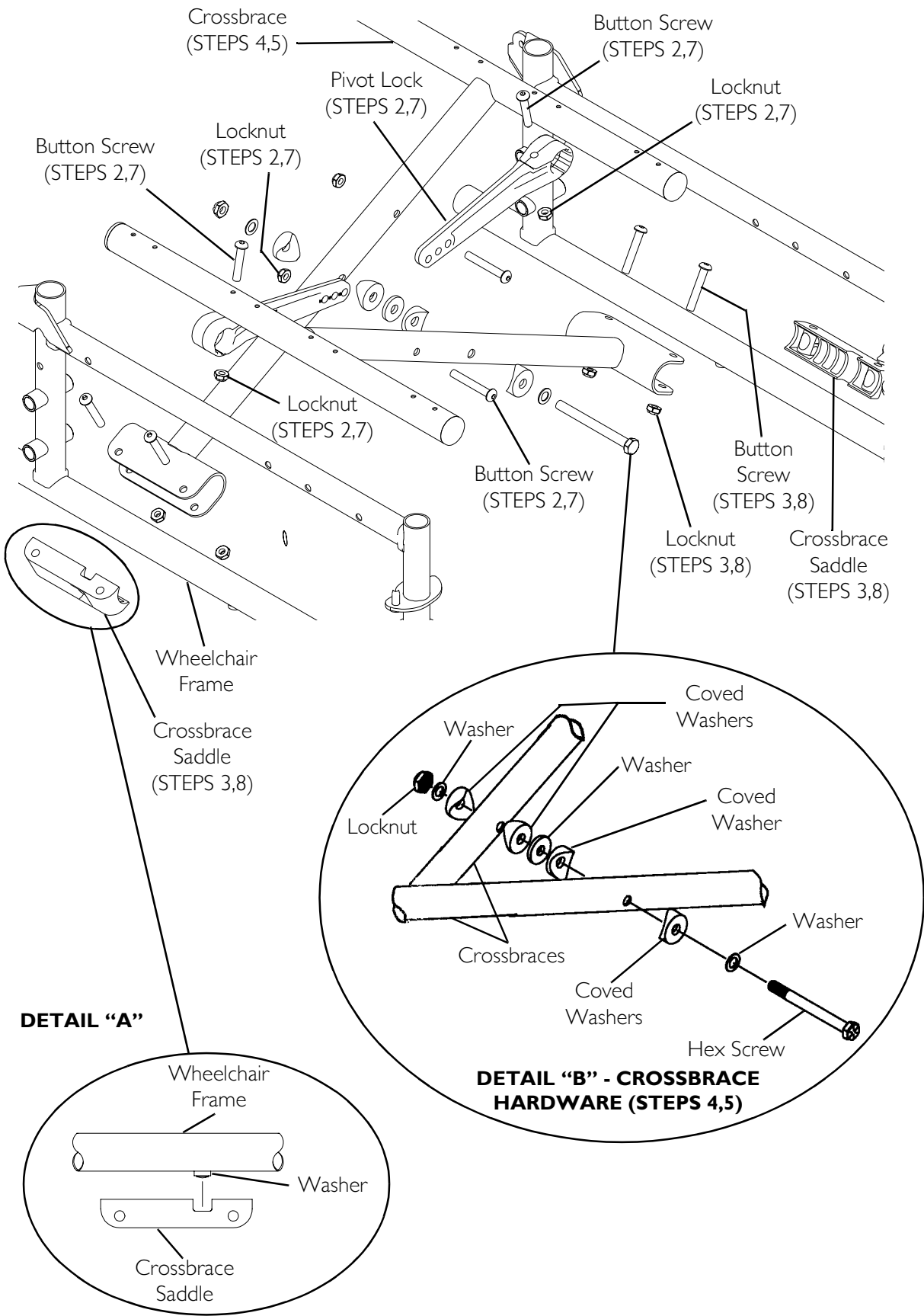

FIGURE 6.4 Adjusting the Seat Width - Swingaway Front Riggings

Fixed Frame

NOTE: For this procedure, refer to FIGURE 6.5.

Removing Lower Mounting Hardware

1. Remove the existing back and seat upholstery from the wheelchair. Refer to Replacing Back Upholstery on page 37 and Replacing Seat Upholstery on page 37.

NOTE: If adjusting the seat width of the wheelchair, back and seat upholstery as well as the crossbraces MUST be replaced.

2. Remove the four screws and locknuts that secure the insert tube to the lower wheelchair frame.
3. Remove the inserts from the rear of the wheelchair.
4. Remove the hex screw and locknut that secure the two existing crossbraces together.

Removing Upper Mounting Hardware

1. While pushing down on the rear seat guide, pull up the front seat guide until the front seat guide releases from the wheelchair frame.
2. Pull the crossbrace away from the rear seat guide.
3. Repeat STEPS 1-2 for opposite crossbrace.
4. Reverse STEPS 1-3 to assemble the upper mounting hardware.
5. Reverse STEPS 1-4 in Removing Lower Mounting Hardware.

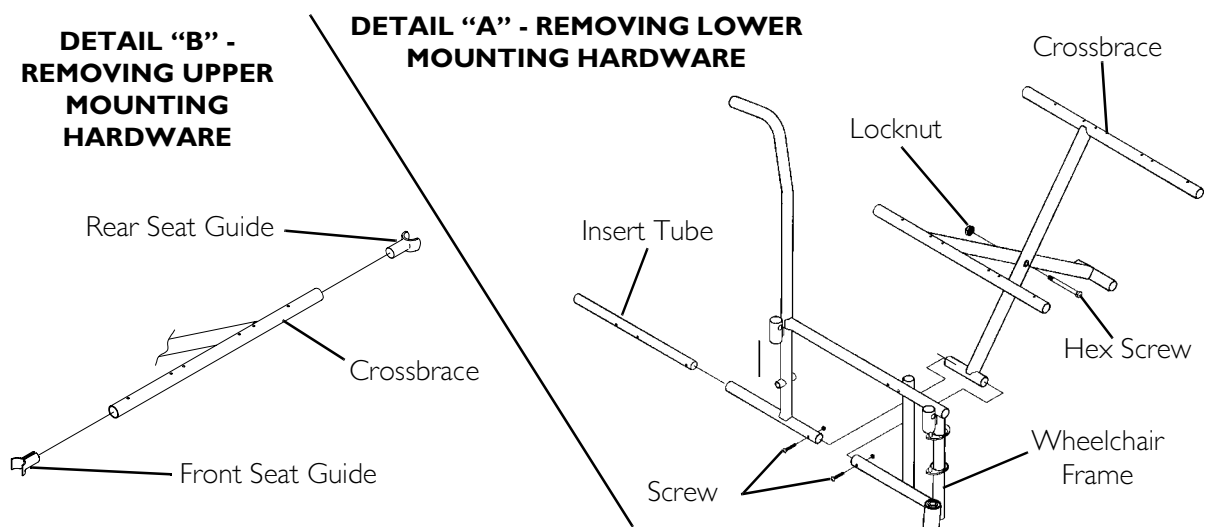

FIGURE 6.5 Adjusting the Seat Width - Fixed Frame

SECTION 7—REAR WHEELS

⚠ WARNING

After any adjustments, repair or service and before use, make sure all attaching hardware is tightened securely. Otherwise injury or damage may occur.

Removing/Installing Rear Wheels

⚠ WARNING

Only a qualified technician may change the size of the rear wheel or the seat-to-floor height.

If changing the size of the rear wheel or a change in the Seat-to-Floor Height is desired, this procedure **MUST** be performed by a qualified technician.

Make sure both rear wheels are the same size and are installed into the same respective mounting hole **BEFORE** using the wheelchair, otherwise injury may occur.

Permanent Axles

⚠ WARNING

This procedure **MUST** be performed by a qualified technician.

NOTE: For this procedure, refer to FIGURE 7.1.

NOTE: If replacing the same size rear wheel, note the mounting position on the wheelchair frame for proper reinstallation of the new rear wheel.

1. Remove the dust cap (SA Frame only), hex screw, washer (SA Frame only), spacer (if installed) and locknut that secure the rear wheel to the wheelchair frame.

NOTE: The spacer is used on wheelchairs with removable arms only.

2. Repeat STEP 1 for the opposite rear wheel if desired.
3. To reinstall the rear wheel(s) onto the wheelchair, reverse STEPS 1-2 and torque locknut to 40 ft.-lbs.
4. Adjust wheel locks. Refer to [Using/Adjusting Patient Operated Wheel Locks](#) on page 48.

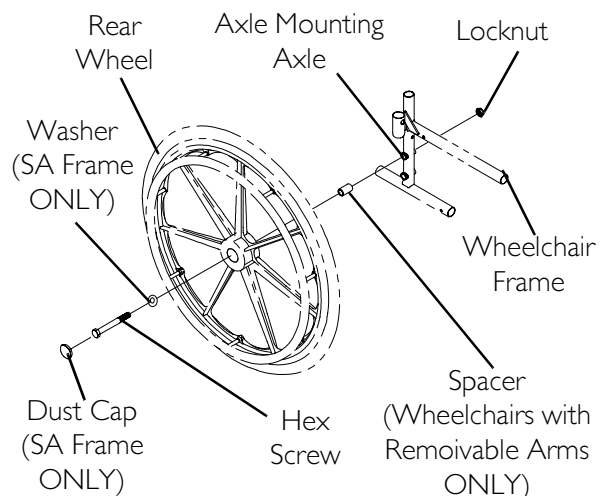

FIGURE 7.1 Removing/Installing Rear Wheels - Permanent Axles

Replacing Rear Wheel Handrim

⚠ WARNING

Wheelchairs with 300lbs weight limit: DO NOT use composite handrims. Otherwise injury or damage may occur.

If the wheelchair is equipped with permanent axles, this procedure MUST be performed by a qualified technician.

NOTE: For this procedure, refer to FIGURE 7.2.

1. Remove the rear wheel from the wheelchair. Refer to [Removing/Installing Rear Wheels](#) on page 41.
2. Remove the mounting screws that secure the handrim to the rear wheel.
3. Remove the existing handrim.
4. Install the new handrim by reversing the preceding steps.

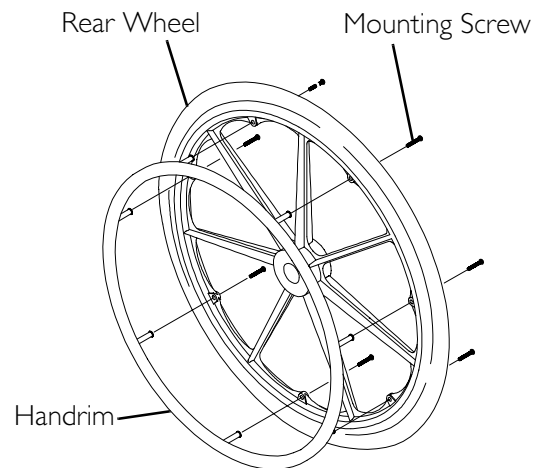

FIGURE 7.2 Replacing Rear Wheel Handrim

⚠ WARNING

Make sure detent pin and detent balls of the quick-release axles are fully released before operating the wheelchair.

5. Reinstall rear wheel to the wheelchair. Refer to [Removing/Installing Rear Wheels](#) on page 41.
6. Repeat STEPS 1-5 for the opposite rear wheel if necessary.

Replacing/Repairing Rear Wheel Tire

⚠ WARNING

Replacement of rear wheel tire MUST be performed by a qualified technician.

CAUTION

As with any vehicle, the wheels and tires should be checked periodically for cracks and wear, and should be replaced if damaged.

SECTION 8—FRONT CASTERS

⚠ WARNING

After any adjustments, repair or service and before use, make sure all attaching hardware is tightened securely. Otherwise injury or damage may occur.

Installing/Replacing Six or Eight-Inch Front Casters and Forks

⚠ WARNING

Make sure both fork/caster assemblies are the same size **BEFORE** using the wheelchair, otherwise injury may occur.

NOTE: For this procedure, refer to FIGURE 8.1.

NOTE: This procedure can be performed if replacing the exact same size front caster.

1. Remove the dust cover.
2. Remove the locknut and nylon washer that secures the fork to the caster headtube.
3. Drop the fork assembly out of the caster headtube.

NOTE: If caster replacement is desired, refer to Replacing/Repairing Front Caster Tire on page 45.

4. Slide the new fork assembly into the caster headtube.
5. Reassemble by reversing STEPS 1-3.
6. Repeat STEPS 1-6 for the opposite fork assembly.
7. Adjust the forks. Refer to Adjusting Forks on page 44.

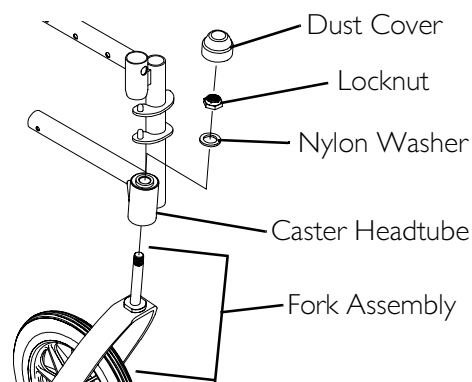

FIGURE 8.1 Installing/Replacing Six or Eight-Inch Front Casters and Forks

Adjusting Forks

1. To properly tighten caster journal system and guard against flutter, perform the following check:
 - A. Tip back of wheelchair to floor.
 - B. Pivot both forks and casters to top of their arc simultaneously.
 - C. Let casters drop to bottom of arc (wheels should swing once to one-side, then immediately rest in a straight downward position).
 - D. Adjust locknuts according to freedom of caster swing.
 - E. Repeat STEPS C-D until wheels swing once to one-side, then immediately rest in a downward position.
2. Test wheelchair for maneuverability.
3. Readjust locknuts if necessary, and repeat STEPS 1-2 until correct.
4. Snap dust cover over the locknut and stem.

Replacing Front Casters

⚠ WARNING

Make sure both front casters are the same size and are installed into the same respective mounting hole before using the wheelchair, otherwise injury may occur.

NOTE: For this procedure, refer to FIGURE 8.2.

NOTE: If replacing the same size front caster, note the mounting position on the fork assembly for proper reinstallation of the new front caster.

1. Remove the hex screw, washers and locknut that secure the front caster to the fork.

NOTE: Washers are only used with 6 and 8-inch casters with precision bearings.

2. To reinstall the new front caster onto the fork, reverse step 1.

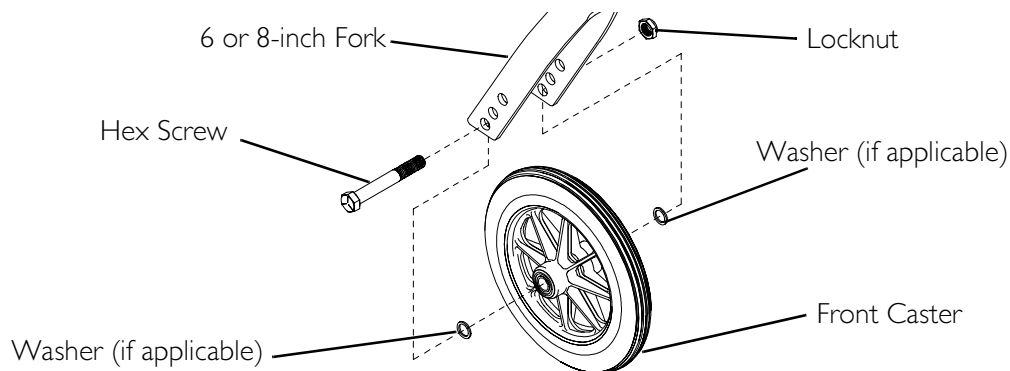

FIGURE 8.2 Replacing Front Casters

Replacing/Repairing Front Caster Tire

WARNING

Replacement of front caster tire **MUST** be performed by a qualified technician.

CAUTION

As with any vehicle, the wheels and tires should be checked periodically for cracks and wear, and should be replaced when necessary.

SECTION 9—ANTI-TIPPERS/WHEEL LOCKS

⚠ WARNING

After any adjustments, repair or service and before use, make sure all attaching hardware is tightened securely. Otherwise injury or damage may occur.

Installing/Adjusting Anti-tippers

⚠ WARNING

Anti-tippers are specific to the different seat-to-floor heights. Refer to the chart in this section of the manual for correct usage and adjustment. If these requirements cannot be achieved, **DO NOT** use the wheelchair. Contact a qualified technician. If changing the seat-to-floor height, the correct anti-tippers must be used to maintain a 1-1/2 to 2-inch ground clearance.

If so equipped, anti-tippers **MUST** be attached at all times. Inasmuch as the anti-tippers are an option on this wheelchair (You may order with or without the anti-tippers), Invacare strongly recommends ordering the anti-tippers as a safeguard for the wheelchair user.

Anti-tippers **MUST** be fully engaged and release buttons fully protruding out of adjustment holes.

ALWAYS use anti-tippers. When outdoors on wet, soft ground or on gravel surfaces, anti tippers may not provide the same level of protection against tipover. Extra caution must be observed when traversing such surfaces.

Ensure both anti-tippers are adjusted to the same mounting hole.

NOTE: For this procedure, refer to FIGURE 9.1 on page 47 and FIGURE 9.2 on page 47.

Installing Anti-Tippers

NOTE: To ensure the correct model anti-tipper is used refer to FIGURE 9.1. Measurements for anti-tippers are approximate and are taken with extension tube in bottom hole position.

WHEELCHAIR MODEL	SEAT-TO-FLOOR HEIGHT IN INCHES	ANTI-TIPPER (MEASUREMENTS IN INCHES)			
		LENGTH	HEIGHT	MODEL	PART NO.
TRACER EX2	17½ to 19½	13½	¾	1360	1058836
TRACER EX2 FF	21	12	2¾	9758	1086190

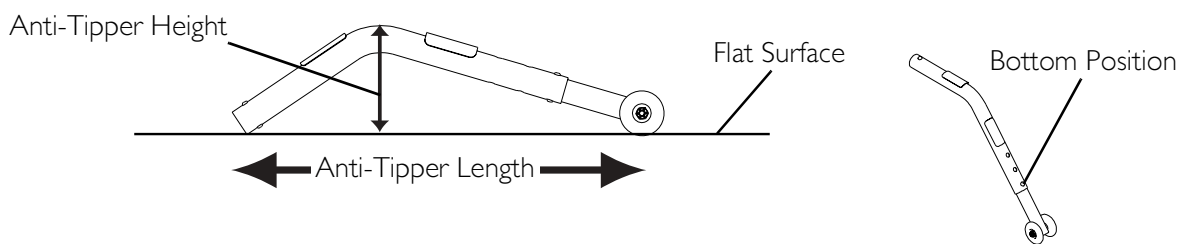

FIGURE 9.1 Installing/Adjusting Anti-tippers - Anti-Tipper Length

1. Press the release buttons and insert the anti-tippers with the anti-tipper wheels pointing toward the ground/floor into the wheelchair frame tubing as shown in FIGURE 9.2.
2. Ensure that the release button of the anti-tipper fully protrudes out of the hole in the bottom of the wheelchair frame tubing.
3. Place the wheelchair on a flat surface.
4. Measure the distance between the bottom of the anti-tipper wheels and the ground/floor.

NOTE: A 1½ to 2-inch clearance between the bottom of the anti-tipper wheels and the ground/floor MUST be maintained at all times.

5. If the distance between the bottom of anti-tipper wheels and the ground/floor is not 1½ to 2-inches, adjust anti-tippers. Refer to Adjusting the Anti-Tippers on page 47.

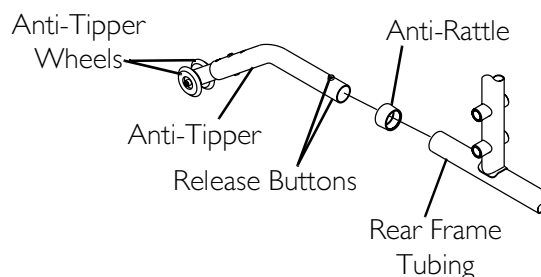

FIGURE 9.2 Installing Anti-Tippers

Adjusting the Anti-Tippers

NOTE: For this procedure, refer to FIGURE 9.3 on page 48.

NOTE: A 1½ to 2-inch clearance between the bottom of the anti-tipper wheels and the ground/floor MUST be maintained at all times.

1. Place the wheelchair on a flat surface.

NOTE: If adjusting anti-tippers on recliner models, ensure back canes are in the upright position BEFORE making adjustments.

2. Press the release buttons on the wheeled portion of the anti-tipper and slide it up or down to the desired adjustment hole.
3. Check to make sure that the release buttons are fully engaged in adjustment holes.
4. Ensure both anti-tippers are adjusted to the same height.
5. Measure the distance between the bottom of the anti-tipper wheels and the ground/floor.

6. If the distance between the bottom of anti-tipper wheels and the ground/floor is not 1½ to 2-inches, repeat STEPS 2-5 until the distance is 1½ to 2-inches.
7. If the 1½ to 2-inch distance cannot be achieved with the anti-tippers, a different model may be required. Contact an Invacare dealer or qualified technician.

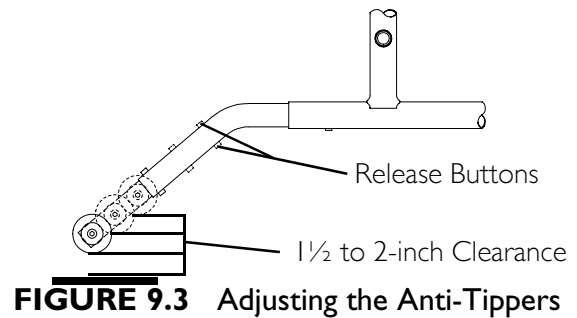

Using/Adjusting Patient Operated Wheel Locks

Using Patient Operated Wheel Locks

⚠ WARNING

DO NOT attempt to stop a moving wheelchair with wheel locks. Wheel locks are not brakes.

NOTE: For this procedure, refer to FIGURE 9.4.

NOTE: Position wheelchair on a flat, level surface to perform this procedure.

1. Ensure the wheelchair is not moving before engaging the wheel locks.
2. Perform one of the following:
 - Push-to-Lock - To engage, push the wheel lock handle forward.
 - Pull-to-Lock - To engage, pull the wheel lock handle backward.
3. Disengage the wheel locks by reversing STEP 2.

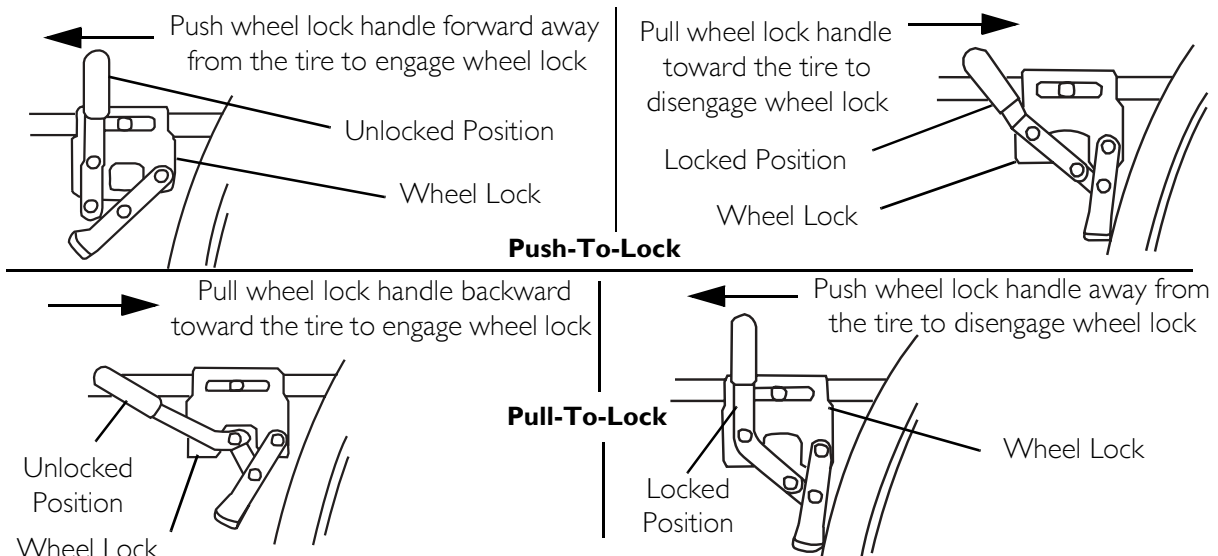

FIGURE 9.4 Using Patient Operated Wheel Locks

Adjusting Patient Operated Wheel Locks

NOTE: For this procedure, refer to FIGURE 9.5.

⚠ WARNING

DO NOT attempt to stop a moving wheelchair with the wheel locks. Wheel locks are not brakes.

NOTE: If wheels are pneumatic, before adjusting the wheel lock assemblies, ensure that the tires are inflated to the recommended psi on the side wall of tire.

1. Disengage the wheel locks.
2. Loosen the bolt and locknut that secure the wheel lock to the wheelchair frame.
3. Reposition the wheel lock so that when engaged, the wheel lock shoe embeds the tire 1/8-inch (3/16-inch for pneumatic tires) and holds the occupied wheelchair in place when pushed.
4. Securely tighten the bolt and locknut attaching the wheel lock to the wheelchair frame.
5. Engage the wheel lock.
6. Measure the distance the wheel lock is embedded into the tire as shown in DETAIL "A" of FIGURE 9.5.

NOTE: Any wheel lock adjustment should embed the wheel lock shoe at least 1/8-inch (3/16-inch if pneumatic tire) into the tire when engaged.

7. Repeat STEPS 1-6 until the wheel lock shoe embeds the tire 1/8-inch (3/16-inch for other tires) and holds the wheelchair in place when pushed.
8. Repeat STEPS 1 - 7 for the opposite wheel lock.
9. If the measurement of 1/8-inch (3/16-inch for other tires) can not be achieved, remove the bolt and locknut that secure the wheel lock to the wheelchair frame and mount the wheel lock in the remaining mounting position.
10. Repeat STEPS 1 - 8.
11. Engage both wheel locks and ensure the occupied wheelchair is held in place when pushed.

⚠ WARNING

If wheel locks do not hold the occupied wheelchair in place, contact a qualified technician; otherwise injury or damage may occur.

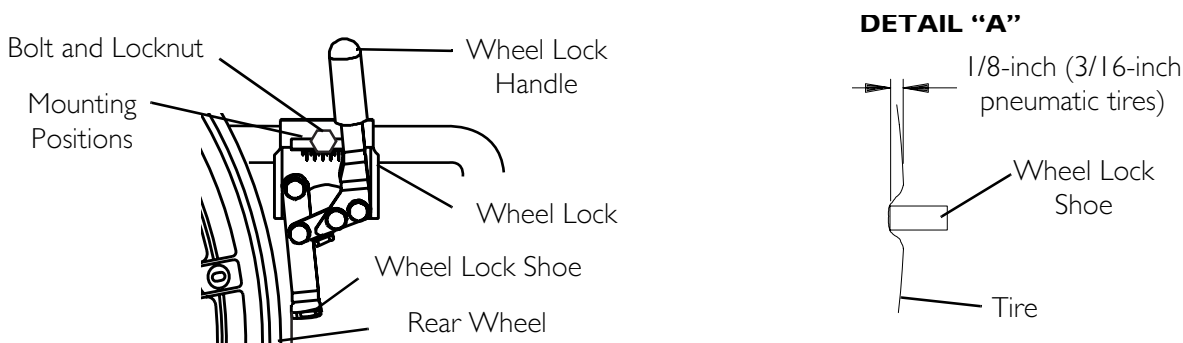

FIGURE 9.5 Adjusting Patient Operated Wheel Locks

SECTION 10—SEAT TO FLOOR

⚠ WARNING

After any adjustments, repair or service and before use, make sure all attaching hardware is tightened securely. Otherwise injury or damage may occur.

NOTE: Seat-to-floor height is not adjustable for Tracer EX2 wheelchairs with the fixed frame option (FF). This procedure is for EX2 wheelchairs with swingaway footrests ONLY.

Changing Seat-to-Floor Height

⚠ WARNING

The size/position of the front casters, size/position of the rear wheels, use of anti-tipper model, as well as the user condition directly relate to the stability of the wheelchair. Any change to one or any combination of the six may cause the wheelchair to decrease in stability. These adjustments **MUST be performed by a qualified technician.**

Seat-to-floor heights have specific positions depending on rear wheel size, rear wheel position, front caster size and front caster position. These adjustments **MUST be performed by a qualified technician.**

If changing the seat-to-floor height the correct anti-tippers **MUST be ordered to maintain a 1-1/2 to 2-inch ground clearance.**

NOTE: For this procedure, refer to FIGURE 10.1 on page 51.

1. Refer to the following chart in FIGURE 10.1 to determine mounting positions for front casters/forks and rear wheels for the desired obtainable seat-to-floor height:
2. Remove the rear wheels from the wheelchair. Refer to Removing/Installing Rear Wheels on page 41.
3. If necessary, replace the front casters and forks with the casters and forks indicated in the chart. Refer to Replacing Front Casters on page 44 and Installing/Replacing Six or Eight-Inch Front Casters and Forks on page 43.
4. Reinstall the rear wheels onto the wheelchair in the mounting position indicated in the chart. Refer to Removing/Installing Rear Wheels on page 41.
5. Adjust anti-tippers according to new seat-to-floor height. Refer to Installing/Adjusting Anti-tippers on page 46.

8-INCH FRONT CASTERS

SEAT-TO-FLOOR HEIGHT (IN INCHES)	FRONT CASTER MOUNTING POSITION	REAR WHEEL SIZE	REAR WHEEL MOUNTING POSITION
17½	Top	24-inch	Top
19½	Bottom	24-inch	Bottom

DETAIL “A” - REAR WHEEL MOUNTING POSITIONS- ADULT/HEMI FRAME STYLE

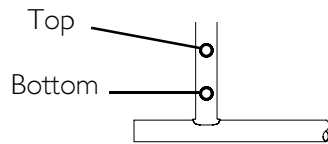

DETAIL “B” - 8-INCH FORK MOUNTING POSITIONS

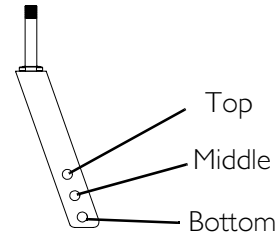

FIGURE 10.1 Changing Seat-to-Floor Height

SECTION 11—OPTIONS

⚠ WARNING

After any adjustments, repair or service and before use, make sure all attaching hardware is tightened securely. Otherwise injury or damage may occur.

Installing Amputee Bracket

NOTE: For this procedure, refer to FIGURE 11.1 on page 53.

1. Refer to the following chart or FIGURE 11.1 to determine the mounting position of the amputee bracket:

SEAT-TO-FLOOR	*BRACKET	AXLE SPACER POSITION (ON BRACKET)	SIDE OF WHEELCHAIR	AXLE MOUNTING POSITION (ON WHEELCHAIR)
ADULT	A	DOWN	RIGHT	TOP
ADULT	B	DOWN	LEFT	TOP
HEMI	B	UP	RIGHT	BOTTOM
HEMI	A	UP	LEFT	BOTTOM

*NOTE: "A" and "B" are stamped on the sides of the amputee bracket.

2. Install the amputee bracket on the wheelchair frame to the position determined in STEP 1.

NOTE: Make sure the axle spacer is pointing towards the outside of the wheelchair.

3. Install the two hex screws and locknuts that secure the amputee bracket to the wheelchair.
4. Install the rear wheels onto the wheelchair. Refer to [Removing/Installing Rear Wheels](#) on page 41.

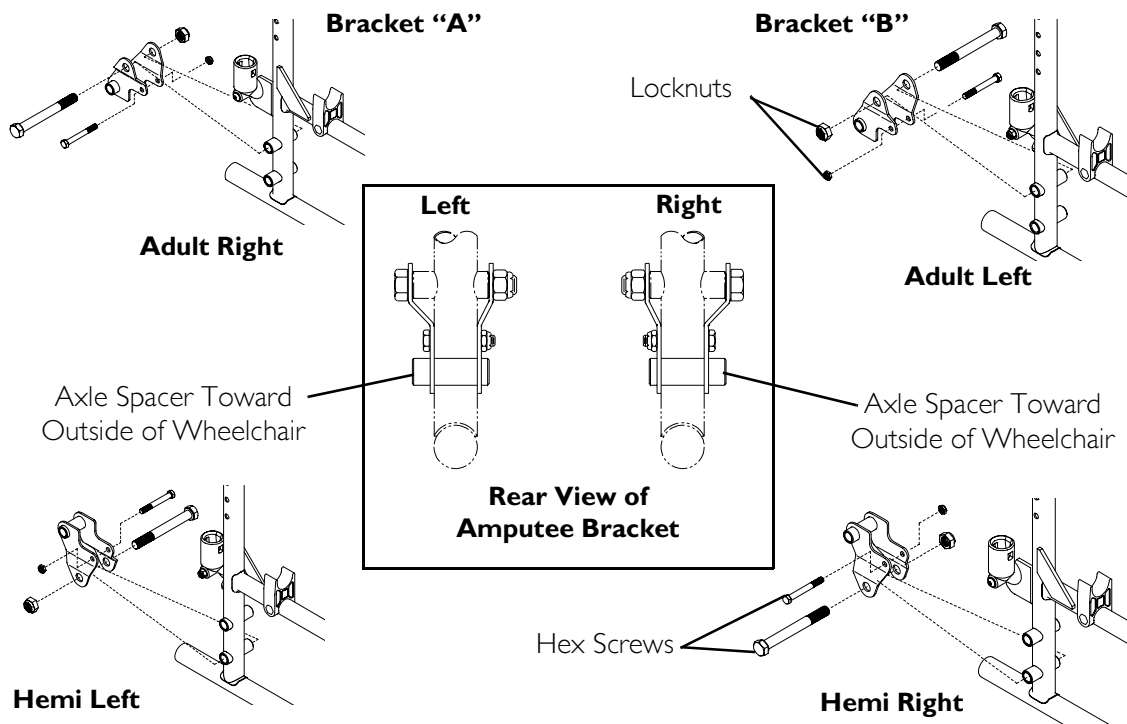

FIGURE 11.1 Installing Amputee Bracket

Installing Crutch and Cane Carrier

⚠ WARNING

Check base weekly to ensure proper placement.

When loading the crutch/cane carrier, ensure items are securely placed into the base. Also ensure that there is no interference with folding the wheelchair, the rear wheels, or the swing-back arms.

Strap must be securely fastened while carrying items.

NEVER insert or remove items while wheelchair is moving.

NOTE: For this procedure, refer to FIGURE 11.2 on page 54.

1. Slide the clamp with the base attached over the end of the step tube of the wheelchair. Ensure the base is towards the inside of the wheelchair.
2. Position the base parallel to the step tube.

CAUTION

Base should be parallel to step tube to avoid bending spokes when folding the wheelchair.

3. Securely tighten the locknut that secures the base to the step tube of the wheelchair.
4. Remove the upper back upholstery screw and washer.
5. Align the strap with the back upholstery screw mounting hole.

6. Reinstall the back upholstery screw and washer and secure the strap to the wheelchair.
7. The base cleans easily with any chrome or glass cleaner. The strap can be cleaned with mild soap and water.

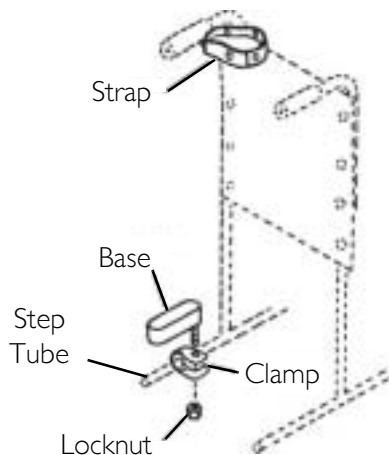

FIGURE 11.2 Installing Crutch and Cane Carrier

Installing the Seat Positioning Strap

⚠ WARNING

ALWAYS wear your positioning strap. Inasmuch as the seat positioning strap is an option on this wheelchair (You may order with or without the seat restraint), Invacare strongly recommends ordering the seat positioning strap as an additional safeguard for the wheelchair user.

NOTE: For this procedure, refer to FIGURE 11.3.

1. Remove the bottom back upholstery screw from the wheelchair.
2. Position the seat positioning strap half between the back cane and back upholstery.
3. Secure the back upholstery and seat positioning strap to the wheelchair with the existing back upholstery screw.
4. Repeat STEPS 1-3 for the opposite side of the wheelchair.

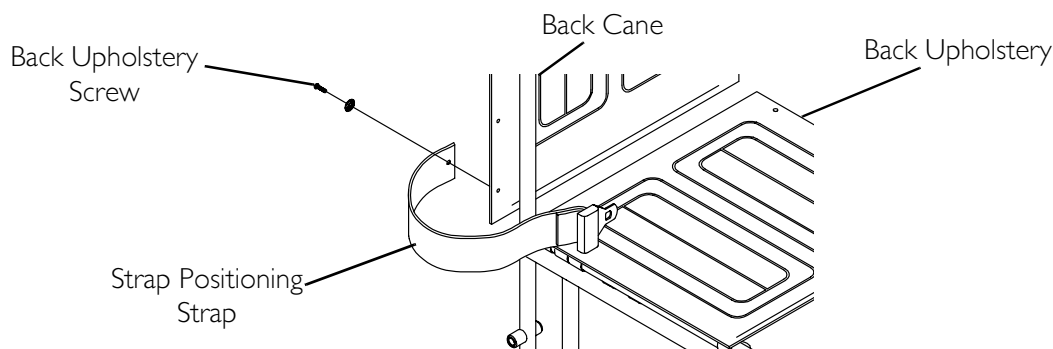

FIGURE 11.3 Installing the Seat Positioning Strap

LIMITED WARRANTY

PLEASE NOTE: THE WARRANTY BELOW HAS BEEN DRAFTED TO COMPLY WITH FEDERAL LAW APPLICABLE TO PRODUCTS MANUFACTURED AFTER JULY 4, 1975.

This warranty is extended only to the original purchaser who purchases this product when new and unused from Invacare or a dealer. This warranty is not extended to any other person or entity and is not transferable or assignable to any subsequent purchaser or owner. Coverage under this warranty will end upon any such subsequent sale or other transfer of title to any other person.

This warranty gives you specific legal rights and you may also have other legal rights which vary from state to state.

Invacare warrants the side frames and cross members of this product when purchased new and unused to be free from defects in materials and workmanship for a period of five (5) years from the date of purchase from Invacare or a dealer, with a copy of the seller's invoice required for coverage under this warranty. Invacare warrants the upholstered materials (seat, back and armrests of the arm assembly) and remaining components of this product when purchased new and unused to be free from defects in materials and workmanship for a period of thirteen (13) months from date of purchase from Invacare or a dealer, with a copy of the seller's invoice required for coverage under this warranty. If within such warranty periods any such product shall be proven to be defective, such product shall be repaired or replaced, at Invacare's option. This warranty does not include any labor or shipping charges incurred in replacement part installation or repair of any such product. Invacare's sole obligation and your exclusive remedy under this warranty shall be limited to such repair and/or replacement.

For warranty service, please contact the dealer from whom you purchased your Invacare product. In the event you do not receive satisfactory warranty service, please write directly to Invacare at the address at the bottom of this page. Provide dealer's name, address, the product model number, date of purchase, indicate nature of the defect and, if the product is serialized, indicate the serial number. Do not return products to our factory without our prior consent.

LIMITATIONS AND EXCLUSIONS: THE FOREGOING WARRANTY SHALL NOT APPLY TO SERIAL NUMBERED PRODUCTS IF THE SERIAL NUMBER HAS BEEN REMOVED OR DEFACED, PRODUCTS SUBJECT TO NEGLIGENCE, ACCIDENT, IMPROPER OPERATION, MAINTENANCE OR STORAGE, PRODUCTS MODIFIED WITHOUT INVACARE'S EXPRESS WRITTEN CONSENT INCLUDING, BUT NOT LIMITED TO, MODIFICATION THROUGH THE USE OF UNAUTHORIZED PARTS OR ATTACHMENTS; PRODUCTS DAMAGED BY REASON OF REPAIRS MADE TO ANY COMPONENT WITHOUT THE SPECIFIC CONSENT OF INVACARE, OR TO A PRODUCT DAMAGED BY CIRCUMSTANCES BEYOND INVACARE'S CONTROL, AND SUCH EVALUATION WILL BE SOLELY DETERMINED BY INVACARE. THE WARRANTY SHALL NOT APPLY TO NORMAL WEAR AND TEAR OR FAILURE TO ADHERE TO THE PRODUCT INSTRUCTIONS.

THE FOREGOING EXPRESS WARRANTY IS EXCLUSIVE AND IN LIEU OF ANY OTHER WARRANTIES WHATSOEVER, WHETHER EXPRESS OR IMPLIED, INCLUDING THE IMPLIED WARRANTIES OF MERCHANTABILITY AND FITNESS FOR A PARTICULAR PURPOSE, AND THE SOLE REMEDY FOR VIOLATIONS OF ANY WARRANTY WHATSOEVER, SHALL BE LIMITED TO REPAIR OR REPLACEMENT OF THE DEFECTIVE PRODUCT PURSUANT TO THE TERMS CONTAINED HEREIN. THE APPLICATION OF ANY IMPLIED WARRANTY WHATSOEVER SHALL NOT EXTEND BEYOND THE DURATION OF THE EXPRESS WARRANTY PROVIDED HEREIN. INVACARE SHALL NOT BE LIABLE FOR ANY CONSEQUENTIAL OR INCIDENTAL DAMAGES WHATSOEVER.

SOME STATES DO NOT ALLOW THE EXCLUSION OR LIMITATION OF INCIDENTAL OR CONSEQUENTIAL DAMAGE, OR LIMITATION OF HOW LONG AN IMPLIED WARRANTY LASTS, SO THE ABOVE EXCLUSION AND LIMITATION MAY NOT BE APPLICABLE.

THIS WARRANTY SHALL BE EXTENDED TO COMPLY WITH STATE/PROVINCIAL LAWS AND REQUIREMENTS.



Yes, you can.

Invacare Corporation www.invacare.com

USA
One Invacare Way
Elyria, Ohio USA
44036-2125
800-333-6900

Canada
570 Matheson Blvd E Unit 8
Mississauga Ontario
L4Z 4G4 Canada
800-668-5324

Invacare, the Medallion Design, Yes, you can., and Tracer are registered trademarks of Invacare Corporation.
Teflon is a registered trademark of Dupont Corp.

© 2007 Invacare Corporation

Part No. 1110546

**PRODUCT MADE
IN CHINA**

Rev D- 1/24/07